

# ACCU Actuators

Position Feedback Actuators, Slides, Gantries and Accessories

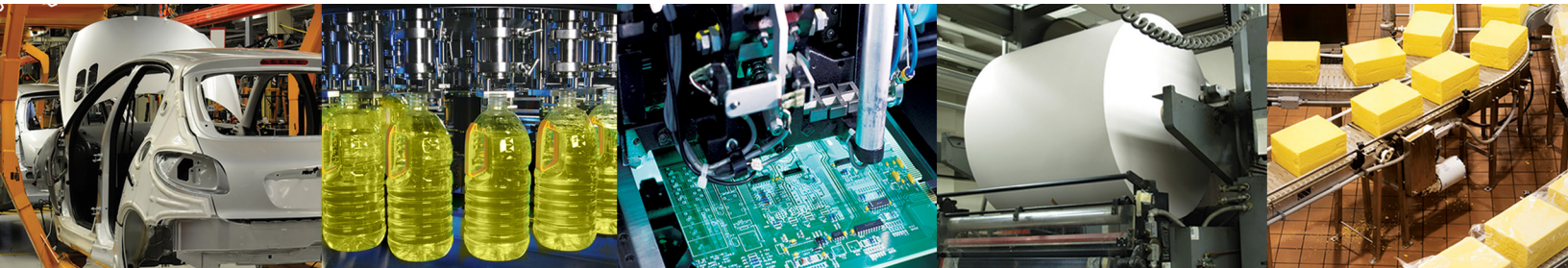

## ACCU Series

<b>ACCU A Series</b>	<b>3-27</b>
Features and Benefits	3
Standard Mounts	4
How To Order	5
Standard and Optional Rod Ends	6
Male Coupling Rod Ends	7
X0 Mount – Basic No Mount	8
E3 Mount – Head Square Mount	9
E4 Mount – Cap Square Mount	9
X1 Mount – Extended Tie Rods - Both Ends	10
X2 Mount – Extended Tie Rods - Cap End	11
X3 Mount – Extended Tie Rods - Head End	12
F1 Mount – Head Rectangular Flange	13
F2 Mount – Cap Rectangular Flange	14
P2 Mount – Detachable Clevis	15
P4 Mount – Detachable Eye	16
S1 Mount – Angle Mount	17
S2 Mount – Side Lugs	18
S4 Mount – Bottom Tapped	19
SN Mount – Sleeve Nut	20
T1 Mount – Head Trunnion	21
T2 Mount – Cap Trunnion	22
T4 Mount – Intermediate Trunnion	23
Accessories	24-25
Accu A Series Piston Rod Assembly How To Order	26
Repair Kit How To Order	27
Seal Kit How To Order	27
Transducer Kit How To Order	27
<b>ACCU M Series</b>	<b>28-32</b>
Features and Benefits	28
How To Order	29
Cylinder Dimensions	30
Block Mount Cylinder Dimensions	31
Accessories	31
Transducer Kit How To Order	32
<b>ACCU Slide Series</b> Features and Benefits	<b>33</b>
<b>ACCU Gantry Series</b> Features and Benefits	<b>34</b>

The **Accu A Series** is an aluminum NFPA Interchangeable cylinder line that contains an internal Linear Resistive Transducer (LRT). It is ideal for applications where traditional magnetic position sensing is not acceptable. Additionally, the Accu A Series is conducive where variations in cylinder stroke and speed are required or where an application calls for continuous position monitoring.

#### Tube

The tube is hard coat anodized on the I.D. The hard coating is an electro-chemical process, which produces a very dense surface of aluminum oxide. This surface has extreme hardness (60 RC.), excellent wear and corrosion resistance, and low coefficient of friction.

#### End Caps

The end caps are accurately machined from (6061-T6) solid aluminum bar stock. They are anodized for corrosion resistance. Additionally, a recess on the piston-mating surface (at both ends) enables the air to work on a larger piston area for effortless breakaway.

#### Rod Bushing

The ACCU Series includes a graphite filled, cast iron rod bushing that is extra long in length. Graphite filled offers the best bearing surface when using a hard chrome plated piston rod. Cast iron provides maximum resistance against wear. The added length adds superior alignment and support of the piston rod as well as provides maximum load bearing support.

#### Rod Seal

The carboxylated nitrile with PTFE compound rod seal is self-lubricating and durable. The rounded lip design ensures proper sealing and long life.

#### Rod Wiper

The standard rod wiper construction is a highly durable polyurethane.

#### Piston Rod

High strength steel (100,000 psi minimum yield) piston rod has a ground, polished, and chrome plated surface. This surface provides maximum life for both the rod bushing and the seals.

#### Bushing Retainer

The bushing retainer allows cartridge removal (cylinder repair) without complete disassembly.

#### Tie Rods

The tie rods are 100,000 psi minimum yield steel for maximum holding power. They are roll formed for superior strength and engagement.

#### Piston Seal

The piston seal is a low friction carboxylated nitrile seal. The carboxylated nitrile is a PTFE compound that is used for self-lubricating. The U-cup seals are pressure activated and wear compensating.

#### Wear Band

The wear band is a stable, lubricating strip located on the piston. We separate the load bearing points by locating the wear band at the rear of the piston. This maximizes column strength at full extension.

#### Piston

The solid aluminum alloy piston is strong and durable.

#### Cushion Seal

The floating cushion seal design enables rapid stroke reversal by providing instantaneous full flow to the piston. Each cushion has a flush, retained adjustment needle.

#### Tube End Seal

The tube end seals are compression type and reusable.

#### Ports

Our enhanced port design enables the cylinder to work more efficiently. Through the use of precise machining depths and tool shape, we are able to smooth the flow path into and out of the cylinder.



#### Linear Resistive Transducer (LRT) Probe

The LRT is an anodized aluminum probe with a reinforced threaded flange and thread seal. The probe processes infinite resolution, with a non-linearity of  $\pm 1$  percent of full stroke. Furthermore, the probe is rated for 10 million cycles. Typical probe input is 10VDC (maximum voltage is 28VDC and maximum current draw is less than 2mA), input impedance required is 1 Mohm. The probe temperature rating is  $-40^{\circ}$  to  $250^{\circ}$  F. Maximum velocity is 50"/sec.

#### Linear Resistive Transducer (LRT) Wiper

The LRT wiper is precision molded assembly that is rated for more than 1000 linear miles of travel.

#### 3 Pin Connector

The customer friendly connector is supplied as standard on all Accu A Series cylinders. The connector has a universal 8 mm, 3 pin, Nano male connection.

### Standard Specifications:

- Meets NFPA mounting dimension specifications
- Bore sizes from 1-1/2" through 8"
- Piston rod diameters from 5/8" to 1-3/4"
- Cylinder maximum pressure rating is 100 psi air
- Standard temperature  $-10^{\circ}$ F to  $165^{\circ}$ F
- Probe Standard Temperature  $-40^{\circ}$ F to  $250^{\circ}$ F
- NPTF ports
- Multitude of mounting options
- Continuous position sensing
- Easily repairable
- Extremely accurate:
  - Infinite resolution, linearity of  $\pm 1$  percent of full stroke,
  - $\pm .001$ " mechanical repeatability
- Electronic controllers available for dual set points and scalable analog output applications
- Quick connect (IP65) standard on all models

**Standard ACCU A Series Mounts**

**Centerline Mounts**

**X0 Mount**  
Basic No Mount  
1-1/2" to 6" Bore

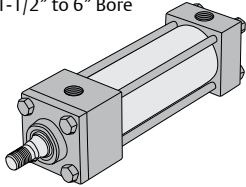

**X1 Mount**  
Extended Tie Rods – Both Ends

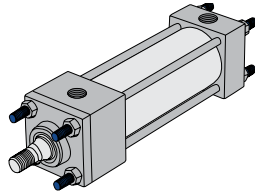

**X2 Mount**  
Extended Tie Rods – Cap End

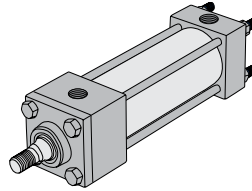

**X3 Mount**  
Extended Tie Rods – Head End

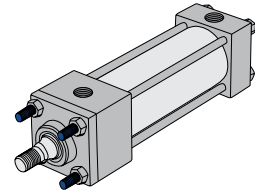

**F1 Mount**  
Head Rectangular Flange  
1-1/2" to 6" Bore

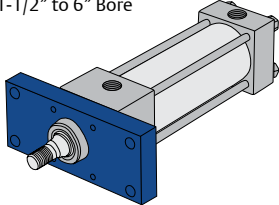

**F2 Mount**  
Cap Rectangular Flange  
1-1/2" to 6" Bore

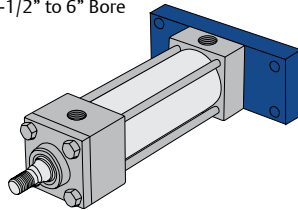

**E3 Mount**  
Head Square  
8" Bore Only

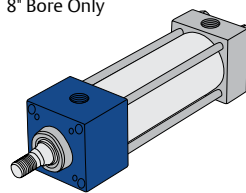

**E4 Mount**  
Head Square  
8" Bore Only

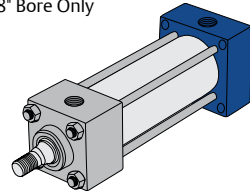

**Pivot Mounts**

**P2 Mount**  
Detachable Clevis

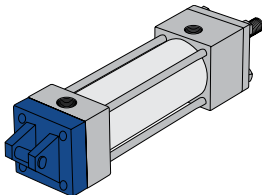

**P4 Mount**  
Detachable Eye

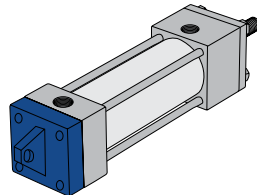

**T1 Mount**  
Head Trunnion

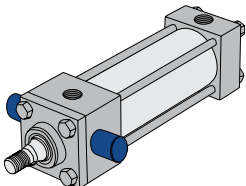

**T2 Mount**  
Cap Trunnion

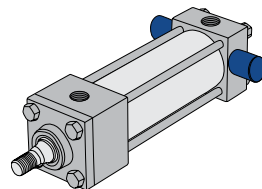

**T4 Mount**  
Intermediate Trunnion

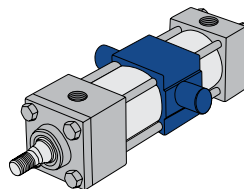

**Foot Mounts**

**S1 Mount**  
Angle Mount

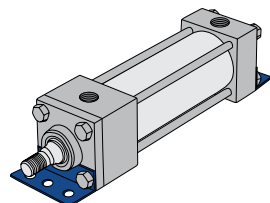

**S2 Mount**  
Side Lugs

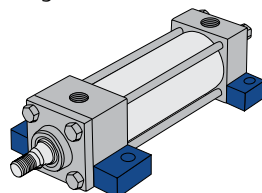

**S4 Mount**  
Bottom Tapped

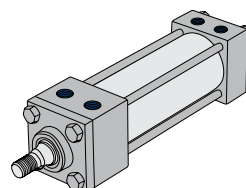

**SN Mount**  
Sleeve Nut

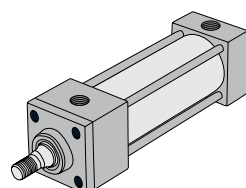

## How to Order

**X0 AAS K - 01 A 3 C - F AA 2 - 4**

### Mount

- X0\* = Standard No Mount
- X1 = Extended Tie Rods Both Ends
- X2 = Extended Tie Rod Cap End
- X3 = Extended Tie Rod Head End
- F1\* = Front Flange
- F2\* = Rear Flange
- E3\*\* = Head Square Flange
- E4\*\* = Cap Square Flange
- P2 = Detachable Clevis
- P4 = Detachable Eye
- T1 = Head Trunnion
- T2 = Cap Trunnion
- T4\*\*\* = Mid Trunnion
- S1 = Angle Mount
- S2 = Side Lug Mount
- S4 = Bottom Tapped
- SN\* = Sleeve Nut
- \* 1-1/2" - 6" bores
- \*\* 8" bore only
- \*\*\*Must specify XI dimension

### Type

- AAS = ACCU A Series

### Bore

- K = 1-1/2" R = 4"
- L = 2" T = 5"
- M = 2-1/2" U = 6"
- P = 3-1/4" W = 8"

### Standard Full Inches of Stroke

- 01 = 1" Stroke
- 02 = 2" Stroke
- 03 = 3" Stroke
- 04 = 4" Stroke
- 06 = 6" Stroke
- 08 = 8" Stroke
- 12 = 12" Stroke
- 18 = 18" Stroke (maximum)

Note: Non-standard stroke lengths increase lead time.

### Fractional Inches of Stroke

- A = 0" I = 1/2"
- B = 1/16" J = 9/16"
- C = 1/8" K = 5/8"
- D = 3/16" L = 11/16"
- E = 1/4" M = 3/4"
- F = 5/16" N = 13/16"
- G = 3/8" O = 7/8"
- H = 7/16" P = 15/16"

Note: Transducers are only available in the "Standard" strokes listed. Non-standard full inch or fractional strokes will use the smallest available "Standard" length transducer to cover the entire stroke. In these cases, the analog output will be less than 10V at full stroke.

### Rod End Codes

- 1 = Style #1 Standard Male Thread
- 2 = Style #2 Optional Male Thread
- 3 = Style #3 Optional Female Thread
- 4 = Special Standard Rod Diameter (must specify threads)
- 5 = Special Oversize Rod Diameter (must specify threads)
- 6 = #1 Oversize Rod Diameter
- 7 = #2 Oversize Rod Diameter
- 8 = #3 Oversize Rod Diameter
- U = Male Coupling Rod End Standard Rod Diameter
- V = Male Coupling Rod End Oversized Rod Diameter

### Position of the Connector Cable

- 1 = Position 1
- 2 = Position 2
- 3 = Position 3
- 4 = Position 4

### Magnet

- 0 = No Magnet
- 2 = Reed Magnet

### Options

- AA = No Options
- BA\* = Bumpers Both Ends
- BC\* = Bumper Cap Only
- BH\* = Bumper Head
- CT = Composite Tube
- CZ = Composite Bushing
- LP = Profile Tubing
- MA = Metallic Rod Scraper
- NA = Nickel Plated
- RB = Rod Boot
- PA = Polypak Rod Seal
- SA = Stainless Steel Piston Rod
- SS = Stainless Piston Rod and Tie Rods
- ST = Stainless Tie Rods
- 1A\* = Rod Extension
- 2A\* = Thread Extension
- 12\* = Rod and Thread Extension
- 3A = Studded Rod End

\* Specify length.

\*\*Bumpers add .062" to OAL (per bumper).

Consult factory for information regarding combination options.

Note: LB Option - Low breakaway seals are standard.

### Head Cushion and Position

Position	1	2	3	4	Fixed
No Cushion	A	A	A	A	A
Head Only	F	G	H	J	W

Note: Cushions are not available on the cap end of the cylinder.

### Port Size and Location

Position	1/8"	1/4"	3/8"	1/2"	3/4"
1	B	C	D	E	F
2	H	I	J	K	L
3	N	O	P	Q	R
4	T	U	V	W	X

Note: Some ports are not available on smaller bore sizes.

## MLRT Circuit Diagram

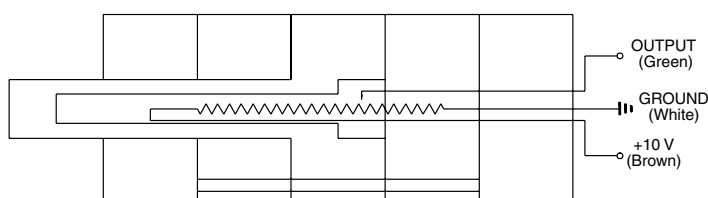

## Connector Pin Assignments

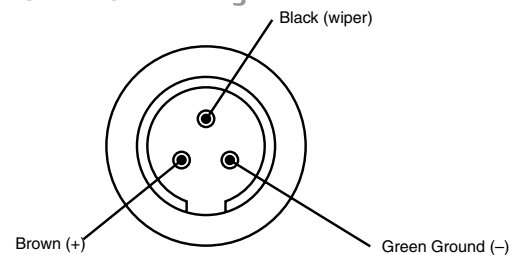

**Dimensions: Inches**

**Standard and Optional Rod Ends**

**1-1/2" - 2-1/2" Bore**

5/8" Rod

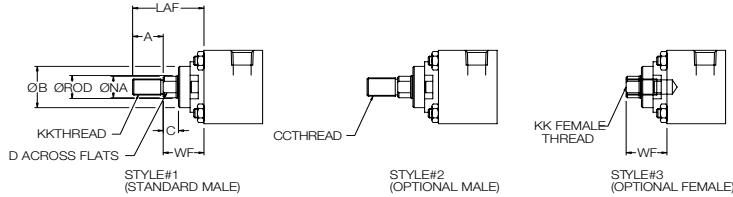

**1-1/2" - 2-1/2" Bore**

1" Rod

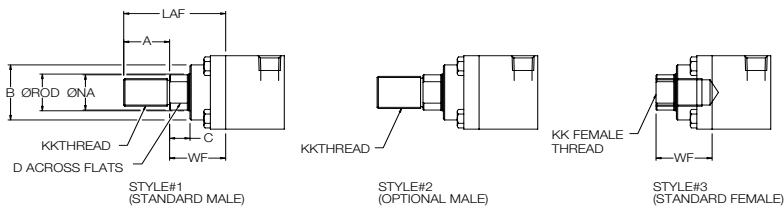

**3-1/4" - 8" Bore**

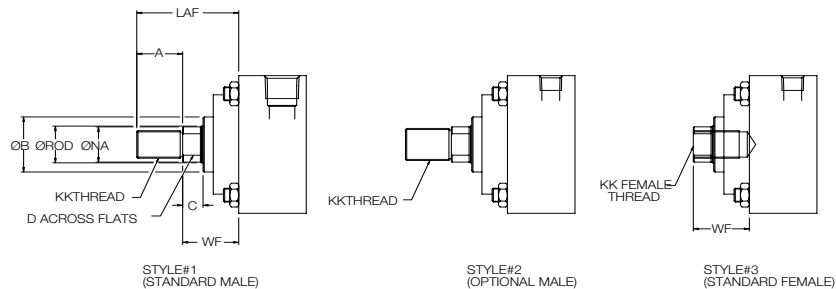

Bore	Rod Diameter	KK	CC	A	B	C	D	NA	LAF	WF
1-1/2	0.625	7/16 - 20	1/2 - 20	0.750	1.125	0.375	0.500	0.585	1.750	1.000
	1.00	3/4 - 16	7/8 - 14	1.125	1.400	0.500	0.813	0.960	2.500	1.375
2	0.625	7/16 - 20	1/2 - 20	0.750	1.125	0.375	0.500	0.585	1.750	1.000
	1.00	3/4 - 16	7/8 - 14	1.125	1.500	0.500	0.813	0.960	2.500	1.375
2-1/2	0.625	7/16 - 20	1/2 - 20	0.750	1.125	0.375	0.500	0.585	1.750	1.000
	1.00	3/4 - 16	7/8 - 14	1.125	1.500	0.500	0.813	0.960	2.500	1.375
3-1/4	1.00	3/4 - 16	7/8 - 14	1.125	1.500	0.500	0.813	0.960	2.500	1.375
	1.375	1 - 14	1 1/4 - 12	1.625	2.000	0.625	1.125	1.313	3.250	1.625
4	1.00	3/4 - 16	7/8 - 14	1.125	1.500	0.500	0.813	0.960	2.500	1.375
	1.375	1 - 14	1 1/4 - 12	1.625	2.000	0.625	1.125	1.313	3.250	1.625
5	1.00	3/4 - 16	7/8 - 14	1.125	1.500	0.500	0.813	0.960	2.500	1.375
	1.375	1 - 14	1 1/4 - 12	1.625	2.000	0.625	1.125	1.313	3.250	1.625
6	1.375	1 - 14	1 1/4 - 12	1.625	2.000	0.625	1.125	1.313	3.250	1.625
	1.750	1 1/4 - 12	1 1/2 - 12	2.000	2.375	0.750	1.500	1.688	3.875	1.875
8	1.375	1 - 14	1 1/4 - 12	1.625	2.000	0.625	1.125	1.313	3.250	1.625
	1.750	1 1/4 - 12	1 1/2 - 12	2.000	2.375	0.750	1.500	1.688	3.875	1.875

Dimensions: Inches

Male Coupling Rod Ends

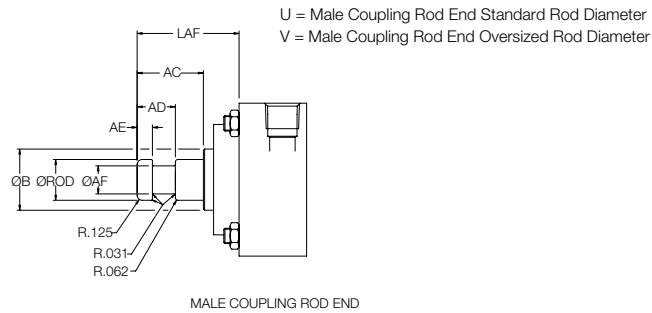

Bore	Rod Diameter	B	AC	AD	AE	AF	LAF
1-1/2	0.625	1.125	1.125	0.625	0.250	0.375	1.750
	1.000	1.500	1.625	0.938	0.375	0.688	2.500
2	0.625	1.125	1.125	0.625	0.250	0.375	1.750
	1.000	1.400	1.625	0.938	0.375	0.688	2.500
2-1/2	0.625	1.125	1.125	0.625	0.250	0.375	1.750
	1.000	1.500	1.625	0.938	0.375	0.688	2.500
3-1/4	1.000	1.500	1.500	0.938	0.375	0.688	2.375
	1.375	2.000	1.750	1.062	0.375	0.875	2.750
4	1.000	1.500	1.500	0.938	0.375	0.688	2.375
	1.375	2.000	1.750	1.062	0.375	0.875	2.750
5	1.000	1.500	1.500	0.938	0.375	0.688	2.375
	1.375	2.000	1.750	1.062	0.375	0.875	2.750
6	1.375	2.000	1.750	1.062	0.375	0.875	2.750
	1.750	2.375	2.000	1.313	0.500	1.125	3.125



**Dimensions: Inches**

**X0 Mount – Basic No Mount**

1-1/2" -2-1/2" Bore  
5/8" Rod

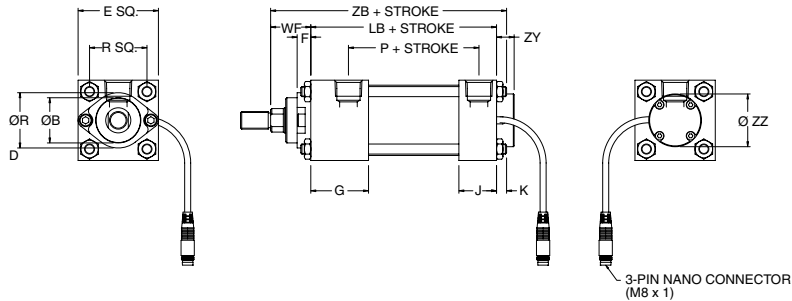

1-1/2" - 2" Bore  
1" Rod

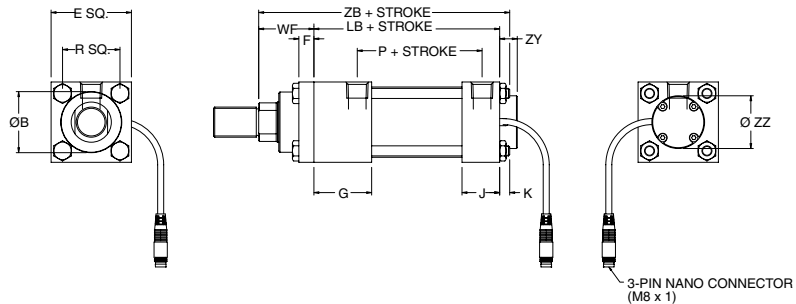

3-1/4" - 6" Bore

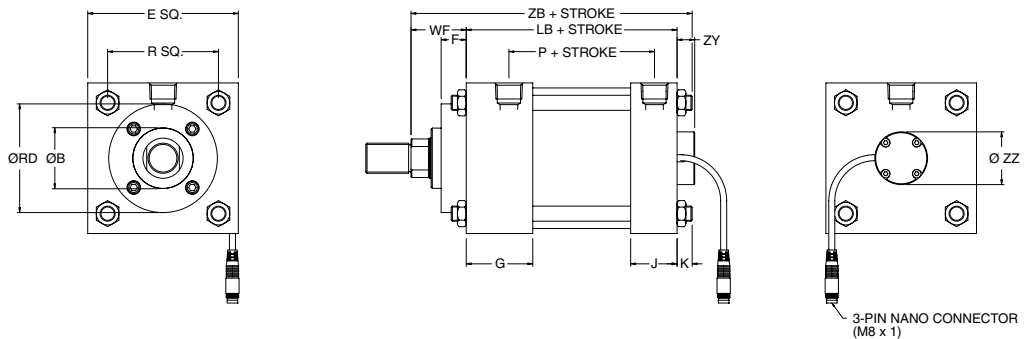

Bore	Rod Diameter	B	E	F	G	J	K	LB	P	R	RD	WF	ZB	ZY	ZZ
1-1/2	0.625	1.125	2.000	0.375	1.500	1.000	0.250	3.625	2.250	1.430	1.375	1.000	4.875	0.438	1.313
	1.000	1.400	2.000	0.375	1.500	1.000	0.250	3.625	2.103	1.430	N/A	1.375	5.250	0.438	1.313
2	0.625	1.125	2.500	0.375	1.500	1.000	0.313	3.625	2.250	1.840	1.375	1.000	4.938	0.438	1.313
	1.000	1.500	2.500	0.375	1.500	1.000	0.313	3.625	2.250	1.840	N/A	1.375	5.313	0.438	1.313
2-1/2	0.625	1.125	3.000	0.375	1.500	1.000	0.313	3.750	2.375	2.190	1.375	1.000	5.062	0.438	1.313
	1.000	1.500	3.000	0.375	1.500	1.000	0.313	3.750	2.375	2.190	N/A	1.375	5.438	0.438	1.313
3-1/4	1.000	1.500	3.750	0.625	1.750	1.250	0.375	4.250	2.625	2.760	2.706	1.375	6.000	0.438	1.313
	1.375	2.000	3.750	0.625	1.750	1.250	0.375	4.250	2.625	2.760	3.125	1.625	6.250	0.438	1.313
4	1.000	1.500	4.500	0.625	1.750	1.250	0.375	4.250	2.625	3.320	2.706	1.375	6.000	0.438	1.313
	1.375	2.000	4.500	0.625	1.750	1.250	0.375	4.250	2.625	3.320	3.125	1.625	6.250	0.438	1.313
5	1.000	1.500	5.500	0.625	1.750	1.250	0.500	4.500	2.875	4.100	2.706	1.375	6.375	0.438	1.313
	1.375	2.000	5.500	0.625	1.750	1.250	0.500	4.500	2.875	4.100	3.125	1.625	6.625	0.438	1.313
6	1.375	2.000	6.500	0.625	2.000	1.500	0.500	5.000	3.125	4.880	3.125	1.625	7.125	0.438	1.313
	1.750	2.375	6.500	0.750	2.000	1.500	0.500	5.000	3.125	4.880	3.788	1.875	7.375	0.438	1.313

1 1/2, 2, & 2-1/2 (with 1" rod) RD dimension is not available. Retainer is full face.



**Dimensions: Inches**

**E3 Mount – Head Square Mount**

8" Bore

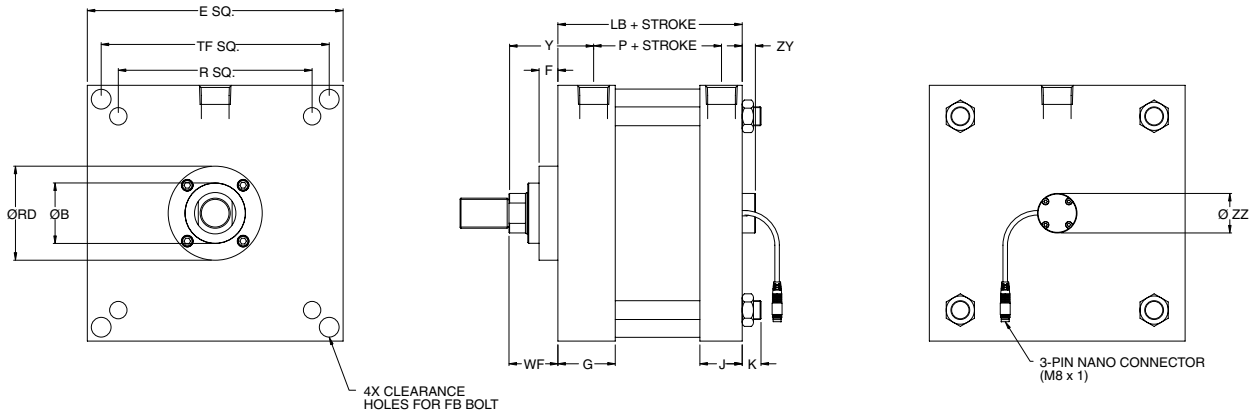

Bore	Rod Diameter	B	E	G	J	F	K	P	R	Y	FB	LB	RD	TF	WF	ZY	ZZ
8	1.375	2.000	8.500	2.000	1.500	0.630	0.630	3.250	6.440	2.810	0.630	5.125	3.130	7.580	1.625	0.438	1.313
	1.750	2.375	8.500	2.000	1.500	0.750	0.630	3.250	6.440	3.060	0.630	5.125	3.790	7.580	1.875	0.438	1.313

**Dimensions: Inches**

**E4 Mount – Cap Square Mount**

8" Bore

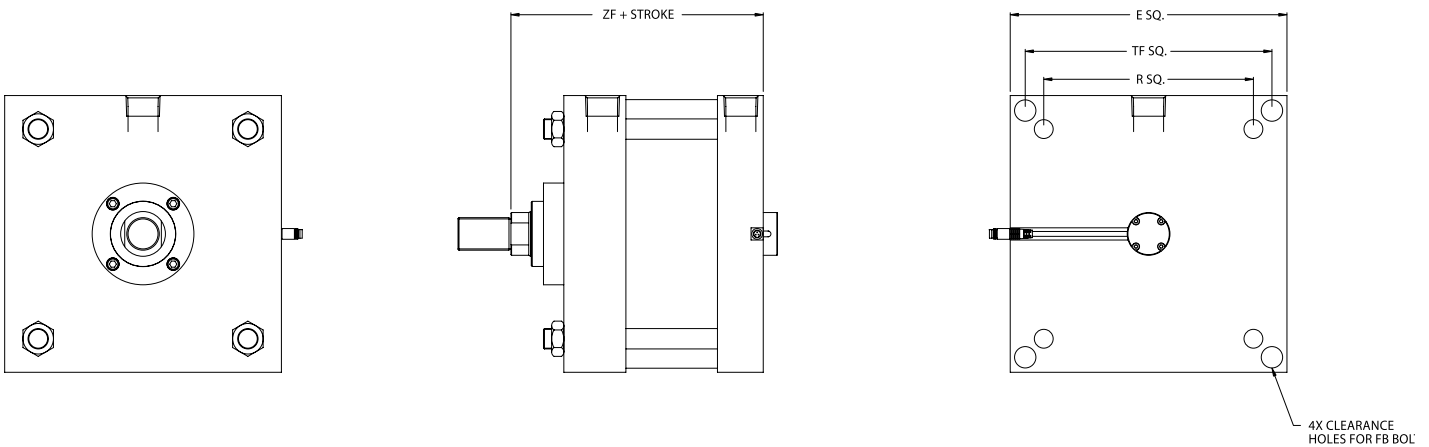

Bore	Rod Diameter	E	R	FB	TF	ZF
8	1.375	8.500	6.440	0.625	7.580	6.750
	1.750	8.500	6.440	0.625	7.580	7.000

**Dimensions: Inches**

**X1 Mount – Extended Tie Rods - Both Ends**

**1-1/2" - 6" Bore**

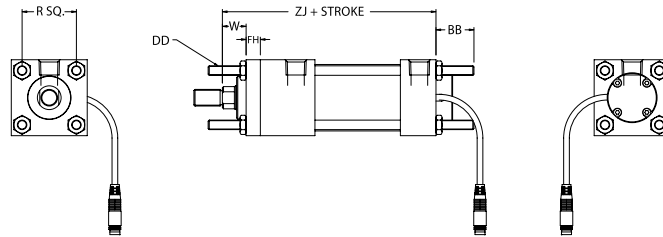

**8" Bore**

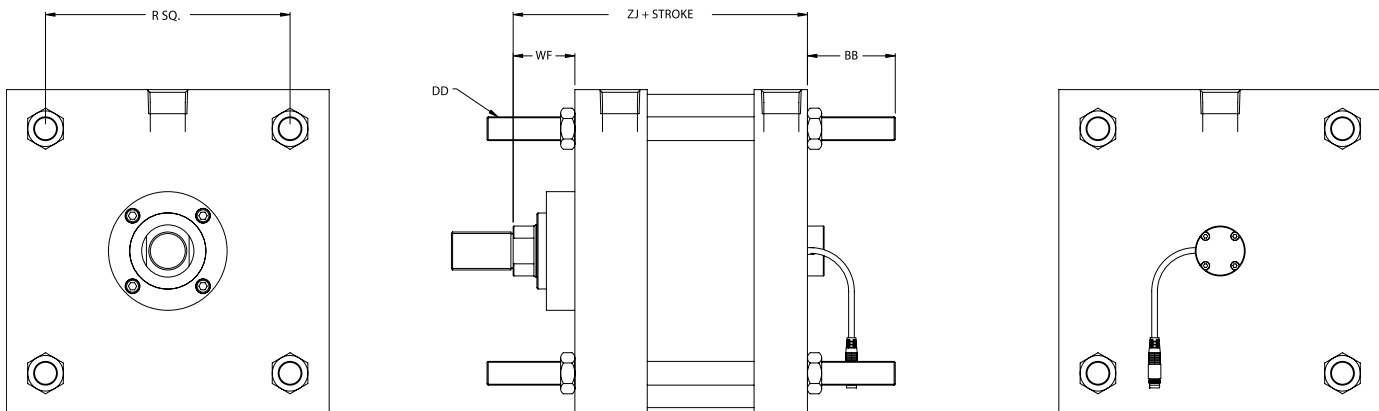

Bore	Rod Diameter	R	W	BB	DD	FH	WF	ZJ
1-1/2	0.625	1.430	0.625	1.000	1/4-28	0.375	N/A	4.625
	1.000	1.430	1.000	1.000	1/4-28	0.375	N/A	5.000
2	0.625	1.840	0.625	1.125	5/16-24	0.375	N/A	4.625
	1.000	1.840	1.000	1.125	5/16-24	0.375	N/A	5.000
2 1/2	0.625	2.190	0.625	1.125	5/16-24	0.375	N/A	4.750
	1.000	2.190	1.000	1.125	5/16-24	0.375	N/A	5.125
3 1/4	1.000	2.760	0.750	1.375	3/8-24	0.625	N/A	5.625
	1.375	2.760	1.000	1.375	3/8-24	0.625	N/A	5.875
4	1.000	3.320	0.750	1.375	3/8-24	0.625	N/A	5.625
	1.375	3.320	1.000	1.375	3/8-24	0.625	N/A	5.875
5	1.000	4.100	0.750	1.813	1/2-20	0.625	N/A	5.875
	1.375	4.100	1.000	1.813	1/2-20	0.625	N/A	6.125
6	1.375	4.880	0.875	1.813	1/2-20	0.750	N/A	6.625
	1.750	4.880	1.125	1.813	1/2-20	0.750	N/A	6.875
8	1.375	6.440	N/A	2.310	5/8-18	N/A	1.625	6.750
	1.750	6.440	N/A	2.310	5/8-18	N/A	1.875	7.000



Dimensions: Inches

X2 Mount – Extended Tie Rods - Cap End

1-1/2" - 2-1/2" Bore

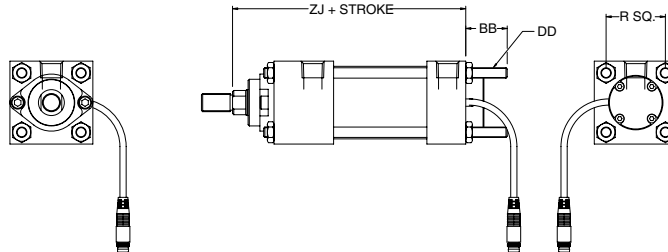

X2 Mount – Extended Tie Rods - Cap End

3-1/4" - 8" Bore

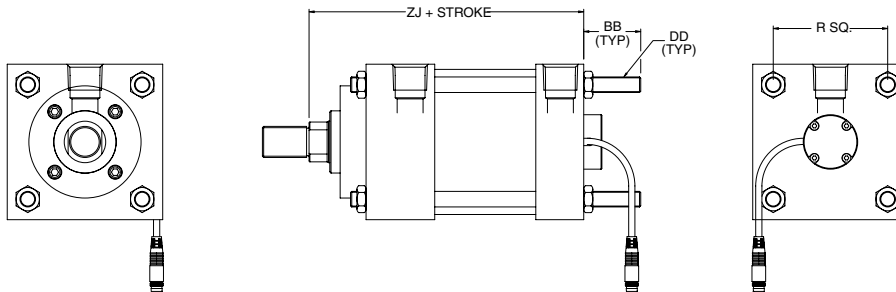

Bore	Rod Diameter	R	BB	DD	ZJ
1-1/2	0.625	1.430	1.000	1/4-28	4.625
	1.000	1.430	1.000	1/4-28	5.000
2	0.625	1.840	1.125	5/16-24	4.625
	1.000	1.840	1.125	5/16-24	5.000
2-1/2	0.625	2.190	1.125	5/16-24	4.750
	1.000	2.190	1.125	5/16-24	5.125
3-1/4	1.000	2.760	1.375	3/8-24	5.625
	1.375	2.760	1.375	3/8-24	5.875
4	1.000	3.320	1.375	3/8-24	5.625
	1.375	3.320	1.375	3/8-24	5.875
5	1.000	4.100	1.813	1/2-20	5.875
	1.375	4.100	1.813	1/2-20	6.125
6	1.375	4.880	1.813	1/2-20	6.625
	1.750	4.880	1.813	1/2-20	6.875
8	1.375	6.440	2.310	5/8-18	6.750
	1.750	6.440	2.310	5/8-18	7.000

**Dimensions: Inches**

**X3 Mount – Extended Tie Rods - Head End**

**1-1/2" - 6" Bore**

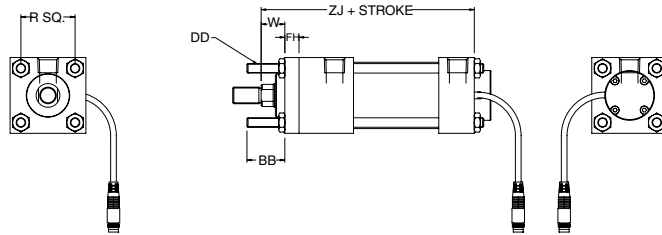

**8" Bore**

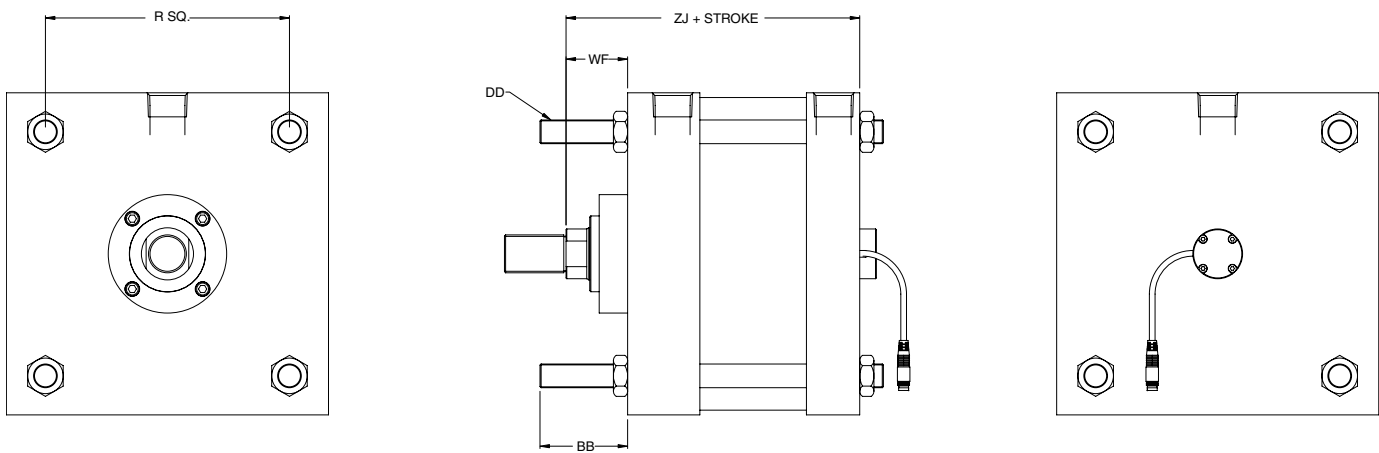

Bore	Rod Diameter	R	W	BB	DD	FH	WF	ZJ
1-1/2	0.625	1.430	0.625	1.000	1/4-28	0.375	N/A	4.625
	1.000	1.430	1.000	1.000	1/4-28	0.375	N/A	5.000
2	0.625	1.840	0.625	1.125	5/16-24	0.375	N/A	4.625
	1.000	1.840	1.000	1.125	5/16-24	0.375	N/A	5.000
2-1/2	0.625	2.190	0.625	1.125	5/16-24	0.375	N/A	4.750
	1.000	2.190	1.000	1.125	5/16-24	0.375	N/A	5.125
3-1/4	1.000	2.760	0.750	1.375	3/8-24	0.625	N/A	5.625
	1.375	2.760	1.000	1.375	3/8-24	0.625	N/A	5.875
4	1.000	3.320	0.750	1.375	3/8-24	0.625	N/A	5.625
	1.375	3.320	1.000	1.375	3/8-24	0.625	N/A	5.875
5	1.000	4.100	0.750	1.813	1/2-20	0.625	N/A	5.875
	1.375	4.100	1.000	1.813	1/2-20	0.625	N/A	6.125
6	1.375	4.880	0.875	1.813	1/2-20	0.750	N/A	6.625
	1.750	4.880	1.125	1.813	1/2-20	0.750	N/A	6.875
8	1.375	6.440	N/A	2.310	5/8-18	N/A	1.625	6.750
	1.750	6.440	N/A	2.310	5/8-18	N/A	1.875	7.000



Dimensions: Inches

F1 Mount – Head Rectangular Flange

1-1/2" - 2-1/2" Bore

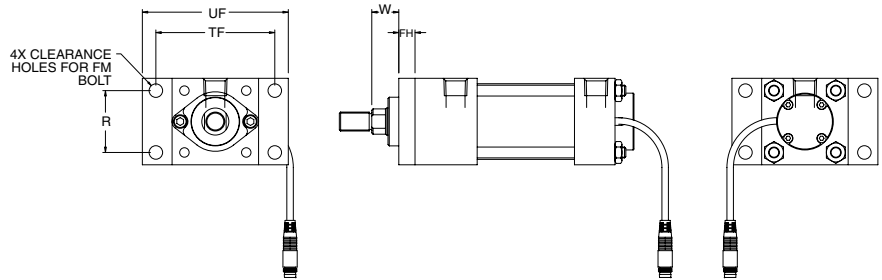

F1 Mount

3-1/4" - 8" Bore

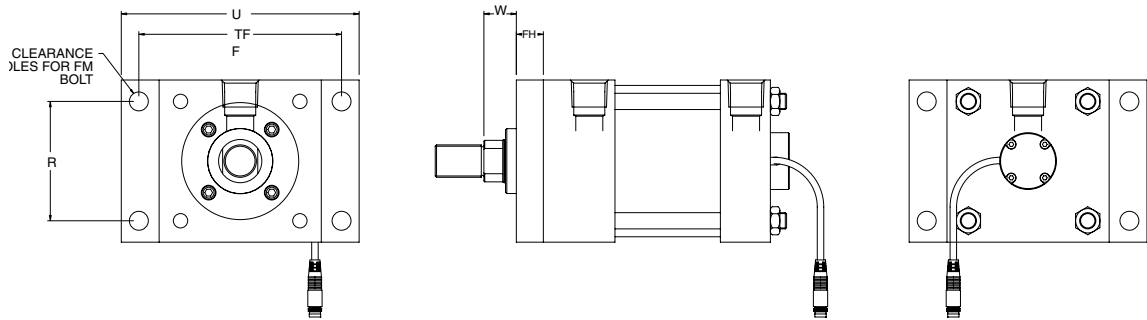

Bore	Rod Diameter	R	W	FB	FH	TF	UF
1-1/2	0.625	1.430	0.625	0.250	0.375	2.750	3.375
	1.000	1.430	1.000	0.250	0.375	2.750	3.375
2	0.625	1.840	0.625	0.313	0.375	3.375	4.125
	1.000	1.840	1.000	0.313	0.375	3.375	4.125
2-1/2	0.625	2.190	0.625	0.313	0.375	3.875	4.625
	1.000	2.190	1.000	0.313	0.375	3.875	4.625
3-1/4	1.000	2.760	0.750	0.375	0.625	4.688	5.500
	1.375	2.760	1.000	0.375	0.625	4.688	5.500
4	1.000	3.320	0.750	0.375	0.625	5.438	6.250
	1.375	3.320	1.000	0.375	0.625	5.438	6.250
5	1.000	4.100	0.750	0.500	0.625	6.625	7.625
	1.375	4.100	1.000	0.500	0.625	6.625	7.625
6	1.375	4.880	0.875	0.500	0.750	7.625	8.625
	1.750	4.880	1.125	0.500	0.750	7.625	8.625

**Dimensions: Inches**

**F2 Mount – Cap Rectangular Flange**

1-1/2" - 2-1/2" Bore

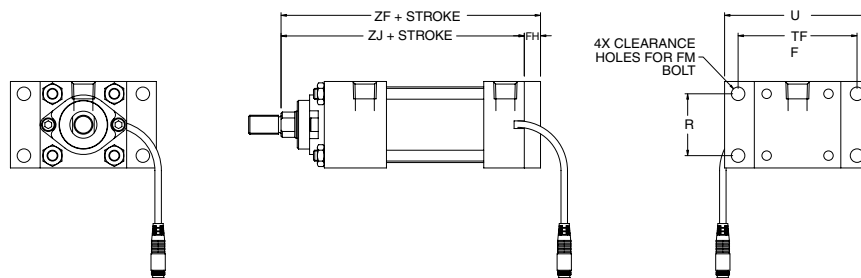

**F2 Mount – Cap Rectangular Flange**

3-1/4" - 6" Bore

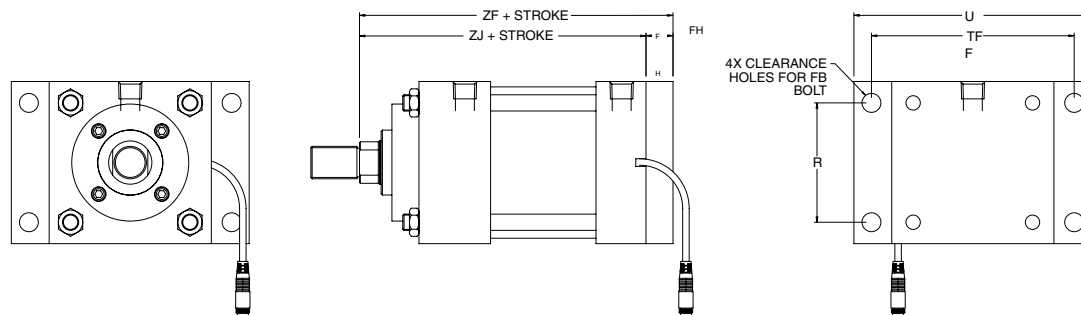

Bore	Rod Diameter	R	FB	FH	TF	UF	ZF	ZJ
1-1/2	0.625	1.430	0.250	0.375	2.750	3.375	5.000	4.625
	1.000	1.430	0.250	0.375	2.750	3.375	5.375	5.000
2	0.625	1.840	0.313	0.375	3.375	4.125	5.000	4.625
	1.000	1.840	0.313	0.375	3.375	4.125	5.375	5.000
2-1/2	0.625	2.190	0.313	0.375	3.875	4.625	5.125	4.750
	1.000	2.190	0.313	0.375	3.875	4.625	5.500	5.125
3-1/4	1.000	2.760	0.375	0.625	4.688	5.500	6.250	5.625
	1.375	2.760	0.375	0.625	4.688	5.500	6.500	5.875
4	1.000	3.320	0.375	0.625	5.438	6.250	6.250	5.625
	1.375	3.320	0.375	0.625	5.438	6.250	6.500	5.875
5	1.000	4.100	0.500	0.625	6.625	7.625	6.500	5.875
	1.375	4.100	0.500	0.625	6.625	7.625	6.750	6.125
6	1.375	4.880	0.500	0.750	7.625	8.625	7.375	6.625
	1.750	4.880	0.500	0.750	7.625	8.625	7.625	6.875

Dimensions: Inches

**P2 Mount – Detachable Clevis**

1-1/2" - 2-1/2" Bore

5/8" Rod

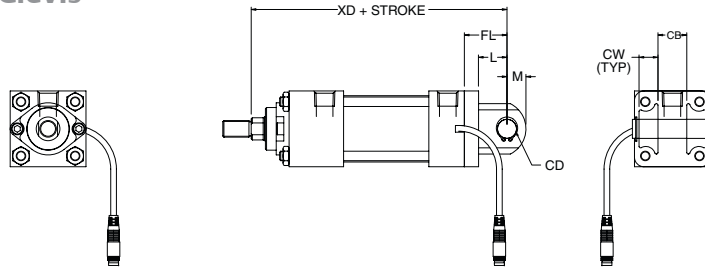

**P2 Mount**

1-1/2" - 2-1/2" Bore

1" Rod

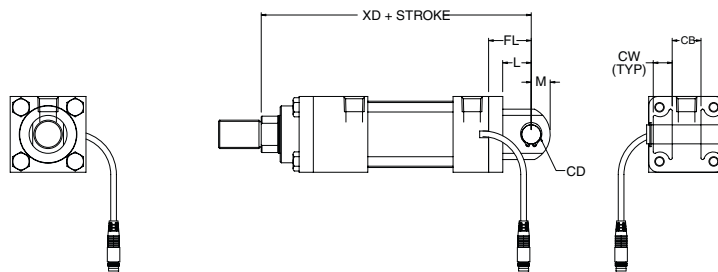

**P2 Mount**

3-1/4" - 8" Bore

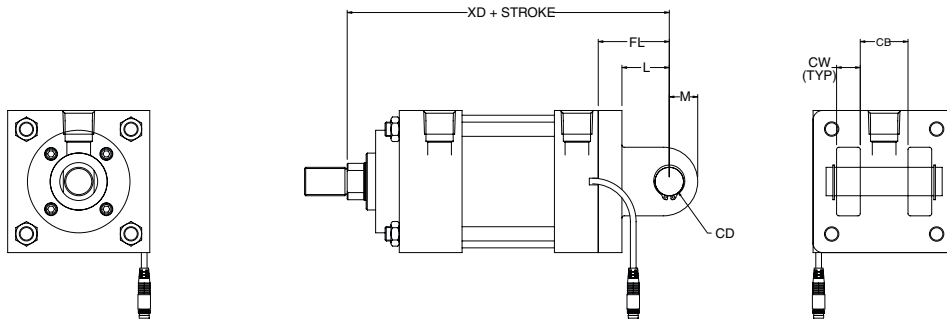

Bore	Rod Diameter	L	M	CB	CD	CW	FL	XD
1-1/2	0.625	0.750	0.500	0.750	0.500	0.500	1.125	5.750
	1.000	0.750	0.500	0.750	0.500	0.500	1.125	6.125
2	0.625	0.750	0.500	0.750	0.500	0.500	1.125	5.750
	1.000	0.750	0.500	0.750	0.500	0.500	1.125	6.125
2-1/2	0.625	0.750	0.500	0.750	0.500	0.500	1.125	5.875
	1.000	0.750	0.500	0.750	0.500	0.500	1.125	6.250
3-1/4	1.000	1.250	0.750	1.250	0.750	0.625	1.875	7.500
	1.375	1.250	0.750	1.250	0.750	0.625	1.875	7.750
4	1.000	1.250	0.750	1.250	0.750	0.625	1.875	7.500
	1.375	1.250	0.750	1.250	0.750	0.625	1.875	7.750
5	1.000	1.250	0.750	1.250	0.750	0.625	1.875	7.750
	1.375	1.250	0.750	1.250	0.750	0.625	1.875	8.000
6	1.375	1.500	1.000	1.500	1.000	0.750	2.250	8.875
	1.750	1.500	1.000	1.500	1.000	0.750	2.250	9.125
8	1.375	1.500	1.000	1.500	1.000	0.750	2.250	9.000
	1.750	1.500	1.000	1.500	1.000	0.750	2.250	9.250



**Dimensions: Inches**

**P4 Mount – Detachable Eye**

**1-1/2" - 2-1/2" Bore, P4 Mount**

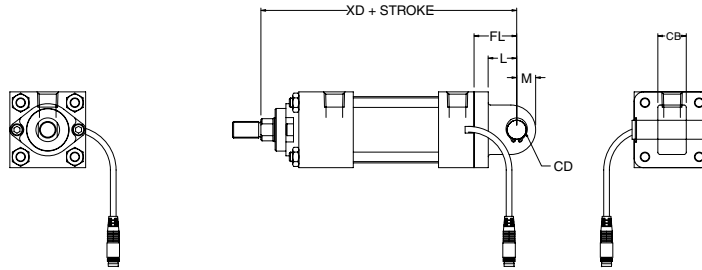

**3-1/4" - 8" Bore, P4 Mount**

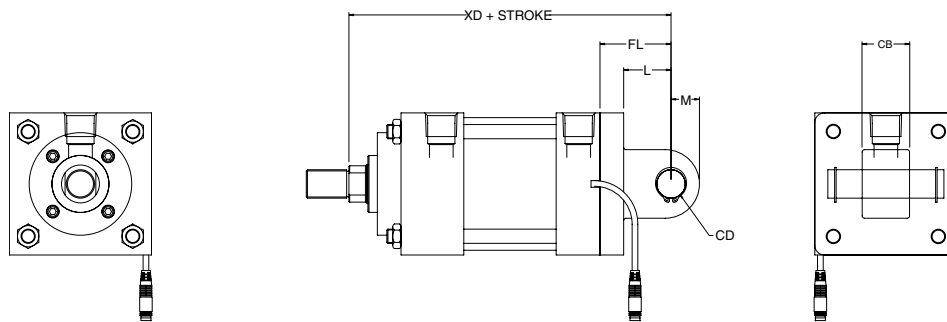

Bore	Rod Diameter	L	M	CB	CD	FL	XD
1-1/2	0.625	0.750	0.500	0.750	0.500	1.125	5.750
	1.000	0.750	0.500	0.750	0.500	1.125	6.125
2	0.625	0.750	0.500	0.750	0.500	1.125	5.750
	1.000	0.750	0.500	0.750	0.500	1.125	6.125
2-1/2	0.625	0.750	0.500	0.750	0.500	1.125	5.875
	1.000	0.750	0.500	0.750	0.500	1.125	6.250
3-1/4	1.000	1.250	0.750	1.250	0.750	1.875	7.500
	1.375	1.250	0.750	1.250	0.750	1.875	7.750
4	1.000	1.250	0.750	1.250	0.750	1.875	7.500
	1.375	1.250	0.750	1.250	0.750	1.875	7.750
5	1.000	1.250	0.750	1.250	0.750	1.875	7.750
	1.375	1.250	0.750	1.250	0.750	1.875	8.000
6	1.375	1.500	1.000	1.500	1.000	2.250	8.875
	1.750	1.500	1.000	1.500	1.000	2.250	9.125
8	1.375	1.500	1.000	1.500	1.000	2.250	9.000
	1.750	1.500	1.000	1.500	1.000	2.250	9.250



Dimensions: Inches

S1 Mount – Angle Mount

1-1/2" - 2-1/2" Bore

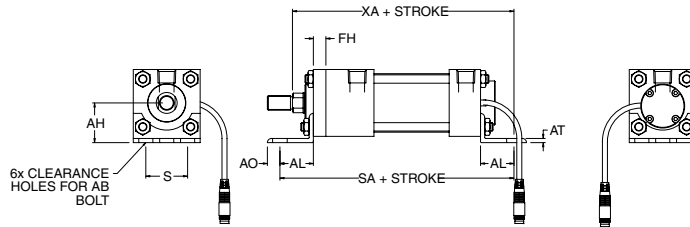

S1 Mount- Angle Mount

3-1/4" - 8" Bore

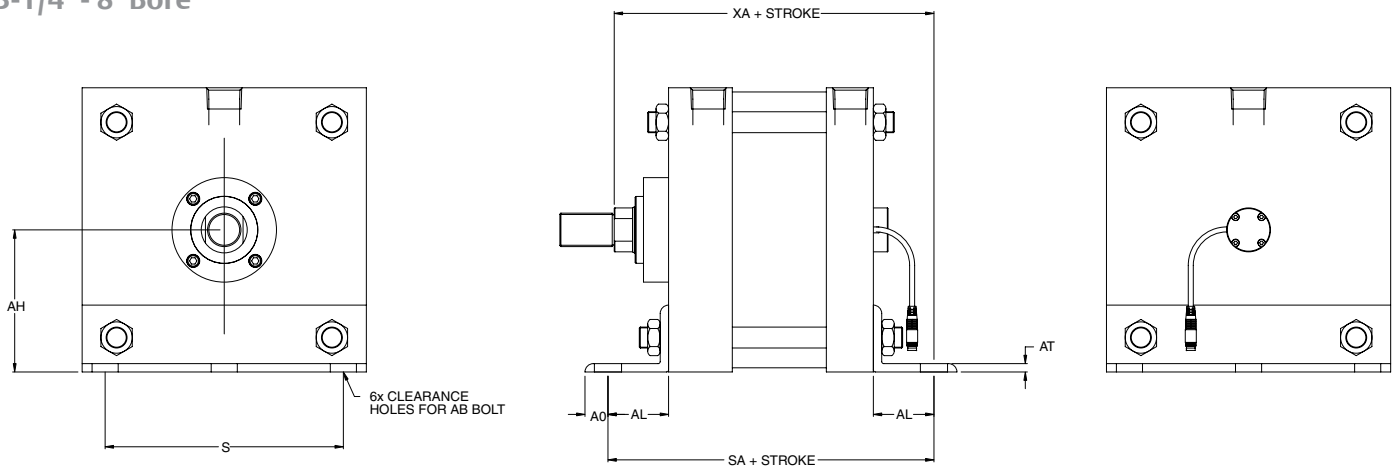

Bore	Rod Diameter	S	AB	AH	AL	AO	AT	FH	SA	XA
1-1/2	0.625	1.250	0.375	1.188	1.000	0.375	0.125	0.375	6.000	5.625
	1.000	1.250	0.375	1.188	1.000	0.375	0.125	0.375	6.000	6.000
2	0.625	1.750	0.375	1.438	1.000	0.375	0.125	0.375	6.000	5.625
	1.000	1.750	0.375	1.438	1.000	0.375	0.125	0.375	6.000	6.000
2-1/2	0.625	2.250	0.375	1.625	1.000	0.375	0.125	0.375	6.125	5.750
	1.000	2.250	0.375	1.625	1.000	0.375	0.125	0.375	6.125	6.125
3-1/4	1.000	2.750	0.500	1.938	1.250	0.500	0.125	0.625	7.375	6.875
	1.375	2.750	0.500	1.938	1.250	0.500	0.125	0.625	7.375	7.125
4	1.000	3.500	0.500	2.250	1.250	0.500	0.125	0.625	7.375	6.875
	1.375	3.500	0.500	2.250	1.250	0.500	0.125	0.625	7.375	7.125
5	1.000	4.250	0.625	2.750	1.375	0.625	0.188	0.625	7.875	7.250
	1.375	4.250	0.625	2.750	1.375	0.625	0.188	0.625	7.875	7.500
6	1.375	5.250	0.750	3.250	1.375	0.625	0.188	0.750	8.500	8.000
	1.750	5.250	0.750	3.250	1.375	0.625	0.188	0.750	8.500	8.250
8	1.375	7.130	0.750	4.250	1.810	0.690	0.250	N/A	8.750	8.560
	1.750	7.130	0.750	4.250	1.810	0.690	0.250	N/A	8.750	8.810

**Dimensions: Inches**

**S2 Mount – Side Lugs**

1-1/2" - 2-1/2" Bore

S2 Mount

5/8" Rod

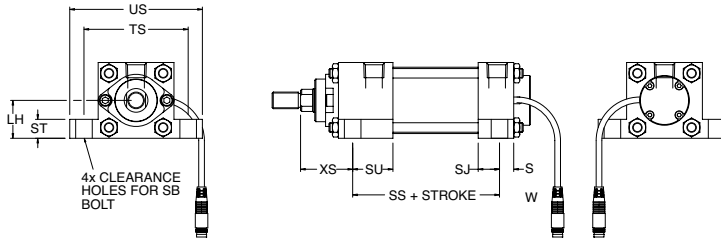

S2 Mount

1-1/2" - 2-1/2" Bore

1" Rod

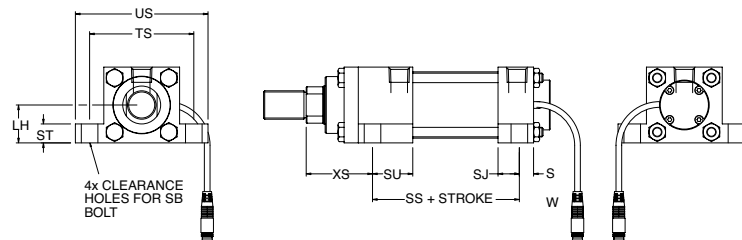

1-1/2" - 8" Bore

S2 Mount

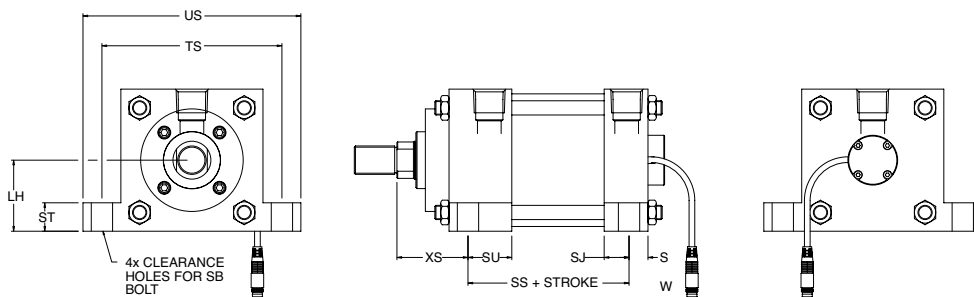

Bore	Rod Diameter	LH	SB	SJ	SS	ST	SU	SW	TS	US	XS
1-1/2	0.625	1.000	0.375	0.625	2.875	0.500	1.125	0.375	2.750	3.500	1.375
	1.000	1.000	0.375	0.625	2.875	0.500	1.125	0.375	2.750	3.500	1.750
2	0.625	1.250	0.375	0.625	2.875	0.500	1.125	0.375	3.250	4.000	1.375
	1.000	1.250	0.375	0.625	2.875	0.500	1.125	0.375	3.250	4.000	1.750
2-1/2	0.625	1.500	0.375	0.625	3.000	0.500	1.125	0.375	3.750	4.500	1.375
	1.000	1.500	0.375	0.625	3.000	0.500	1.125	0.375	3.750	4.500	1.750
3-1/4	1.000	1.875	0.500	0.750	3.250	0.750	1.250	0.500	4.750	5.750	1.875
	1.375	1.875	0.500	0.750	3.250	0.750	1.250	0.500	4.750	5.750	2.125
4	1.000	2.250	0.500	0.750	3.250	0.750	1.250	0.500	5.500	6.500	1.875
	1.375	2.250	0.500	0.750	3.250	0.750	1.250	0.500	5.500	6.500	2.125
5	1.000	2.750	0.750	0.563	3.125	1.000	1.063	0.688	6.875	8.250	2.063
	1.375	2.750	0.750	0.563	3.125	1.000	1.063	0.688	6.875	8.250	2.313
6	1.375	3.250	0.750	0.813	3.625	1.000	1.313	0.688	7.875	9.250	2.313
	1.750	3.250	0.750	0.813	3.625	1.000	1.313	0.688	7.875	9.250	2.563
8	1.375	4.250	0.750	0.813	3.750	1.000	1.313	0.688	9.880	11.250	2.310
	1.750	4.250	0.750	0.813	3.750	1.000	1.313	0.688	9.880	11.250	2.560



Dimensions: Inches

S4 Mount – Bottom Tapped

1-1/2" - 2-1/2" Bore

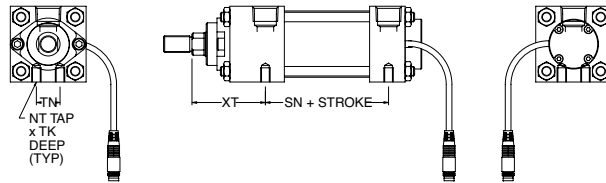

S4 Mount

3-1/4" - 8" Bore

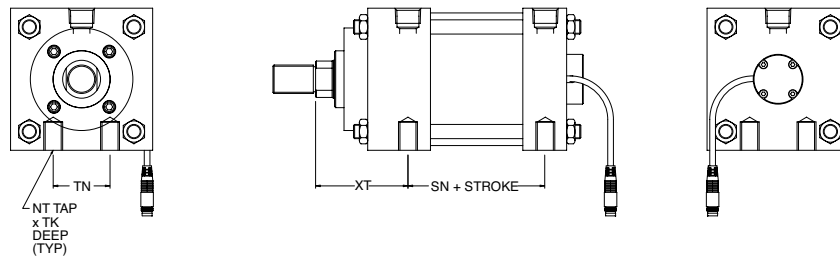

Bore	Rod Diameter	NT	SN	TK	TN	XT
1-1/2	0.625	1/4-20	2.250	0.375	0.625	1.938
	1.000	1/4-20	2.250	0.313	0.625	2.313
2	0.625	5/16-18	2.250	0.500	0.875	1.938
	1.000	5/16-18	2.250	0.500	0.875	2.313
2-1/2	0.625	3/8-16	2.375	0.625	1.250	1.938
	1.000	3/8-16	2.375	0.625	1.250	2.313
3-1/4	1.000	1/2-13	2.625	0.750	1.500	2.438
	1.375	1/2-13	2.625	0.750	1.500	2.688
4	1.000	1/2-13	2.625	0.750	2.063	2.438
	1.375	1/2-13	2.625	0.750	2.063	2.688
5	1.000	5/8-11	2.875	1.000	2.688	2.438
	1.375	5/8-11	2.875	1.000	2.688	2.688
6	1.375	3/4-10	3.125	1.125	3.250	2.813
	1.750	3/4-10	3.125	1.125	3.250	3.063
8	1.375	3/4-10	3.250	1.130	4.500	2.810
	1.750	3/4-10	3.250	1.130	4.500	3.060

**Dimensions: Inches**

**SN Mount – Sleeve Nut**

1-1/2" - 6" Bore

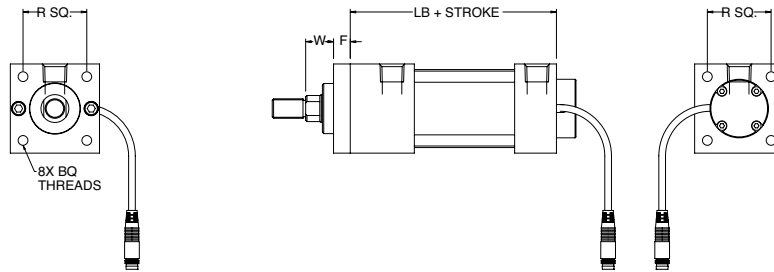

Bore	Rod Diameter	F	R	W	BQ	LB
1-1/2	0.625	0.375	1.430	0.625	1/4-28	3.625
	1.000	0.375	1.430	1.000	1/4-28	3.625
2	0.625	0.375	1.840	0.625	5/16-24	3.625
	1.000	0.375	1.840	1.000	5/16-24	3.625
2-1/2	0.625	0.375	2.190	0.750	5/16-24	3.750
	1.000	0.375	2.190	1.000	5/16-24	3.750
3-1/4	1.000	0.625	2.760	0.750	3/8-24	4.250
	1.375	0.625	2.760	1.000	3/8-24	4.250
4	1.000	0.625	3.320	0.750	3/8-24	4.250
	1.375	0.625	3.320	1.000	3/8-24	4.250
5	1.000	0.625	4.100	0.750	1/2-20	4.500
	1.375	0.625	4.100	1.000	1/2-20	4.500
6	1.375	0.625	4.880	0.875	1/2-20	5.000
	1.750	0.750	4.880	1.125	1/2-20	5.000

Dimensions: Inches

T1 Mount – Head Trunnion

1-1/2"- 2-1/2" Bore

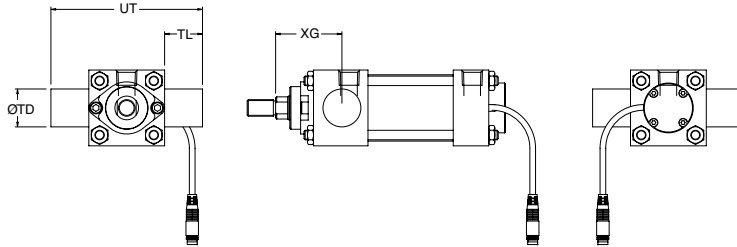

T1 Mount

3-1/4" - 8" Bore

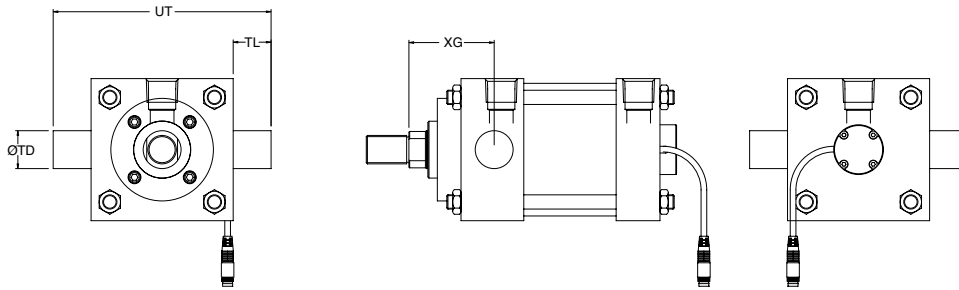

Bore	Rod Diameter	TD	TL	UT	XG
1-1/2	0.625	1.000	1.000	4.000	1.750
	1.000	1.000	1.000	4.000	2.125
2	0.625	1.000	1.000	4.500	1.750
	1.000	1.000	1.000	4.500	2.125
2 1/2	0.625	1.000	1.000	5.000	1.750
	1.000	1.000	1.000	5.000	2.125
3 1/4	1.000	1.000	1.000	5.750	2.250
	1.375	1.000	1.000	5.750	2.500
4	1.000	1.000	1.000	6.500	2.250
	1.375	1.000	1.000	6.500	2.500
5	1.000	1.000	1.000	7.500	2.250
	1.375	1.000	1.000	7.500	2.500
6	1.375	1.375	1.375	9.250	2.625
	1.750	1.375	1.375	9.250	2.875
8	1.375	1.375	1.380	11.250	2.630
	1.750	1.375	1.380	11.250	2.880

**Dimensions: Inches**

**T2 Mount – Cap Trunnion**

1-1/2" - 2-1/2" Bore

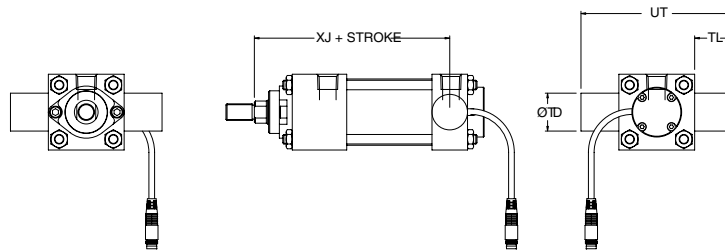

**T2 Mount**

3-1/4" - 8" Bore

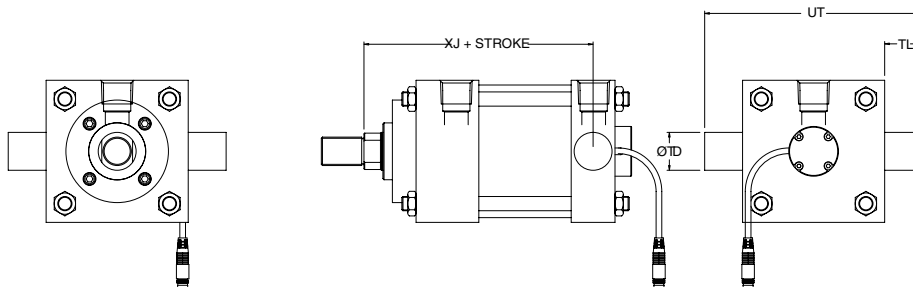

Bore	Rod Diameter	TD	TL	UT	XJ
1-1/2	0.625	1.000	1.000	4.000	4.125
	1.000	1.000	1.000	4.000	4.500
2	0.625	1.000	1.000	4.500	4.125
	1.000	1.000	1.000	4.500	4.500
2-1/2	0.625	1.000	1.000	5.000	4.250
	1.000	1.000	1.000	5.000	4.625
3-1/4	1.000	1.000	1.000	5.750	5.000
	1.375	1.000	1.000	5.750	5.250
4	1.000	1.000	1.000	6.500	5.000
	1.375	1.000	1.000	6.500	5.250
5	1.000	1.000	1.000	7.500	5.250
	1.375	1.000	1.000	7.500	5.500
6	1.375	1.375	1.375	9.250	5.875
	1.750	1.375	1.375	9.250	6.125
8	1.375	1.375	1.380	11.250	6.000
	1.750	1.375	1.380	11.250	6.250



Dimensions: Inches

T4 Mount – Intermediate Trunnion

1-1/2"- 2-1/2" Bore

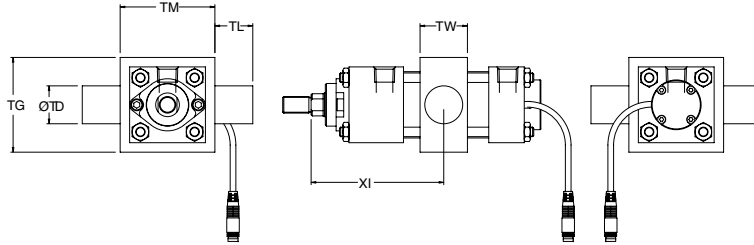

T4 Mount

3-1/4" - 8" Bore

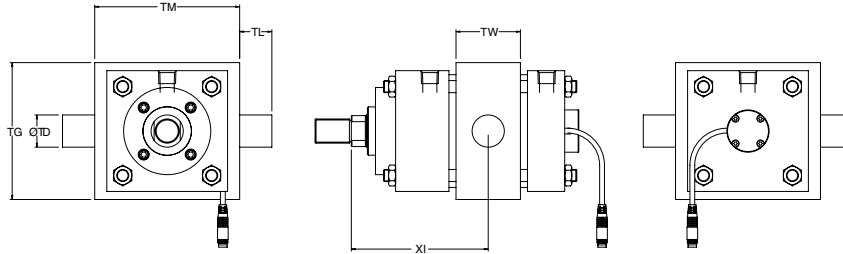

Customer must specify "XI" length.

Bore	Rod Diameter	TD	TG	TL	TM	TW	XI (Min)
1-1/2	0.625	1.000	2.500	1.000	2.500	1.250	3.125
	1.000	1.000	2.500	1.000	2.500	1.250	3.500
2	0.625	1.000	3.000	1.000	3.000	1.500	3.250
	1.000	1.000	3.000	1.000	3.000	1.500	3.625
2-1/2	0.625	1.000	3.500	1.000	3.500	1.500	3.250
	1.000	1.000	3.500	1.000	3.500	1.500	3.625
3-1/4	1.000	1.000	4.250	1.000	4.500	2.000	4.125
	1.375	1.000	4.250	1.000	4.500	2.000	4.375
4	1.000	1.000	5.000	1.000	5.250	2.000	4.125
	1.375	1.000	5.000	1.000	5.250	2.000	4.375
5	1.000	1.000	6.000	1.000	6.250	2.000	4.125
	1.375	1.000	6.000	1.000	6.250	2.000	4.375
6	1.375	1.375	7.000	1.375	7.625	2.500	4.875
	1.750	1.375	7.000	1.375	7.625	2.500	5.125
8	1.375	1.375	9.500	1.380	9.750	2.500	4.880
	1.750	1.375	9.500	1.380	9.750	2.500	5.130

Accessories

Accessories Guide

Rod Thread	Rod Clevis	Eye Bracket	Pivot PIN	Rod Eye	Clevis Bracket	Bore
7/16-20	A500-301	A500-101	A500-401	A500-201	A500-001	1 1/2, 2, 2 1/2
1/2-20	A500-302	A500-101	A500-401	A500-202	A500-001	1 1/2, 2, 2 1/2
3/4-16	A500-303	A500-102	A500-402	A500-203	A500-002	3 1/4, 4, 5
7/8-14	A500-304	A500-102	A500-403	-	-	-
1-14	A500-305	A500-103	A500-403	A500-204	A500-003	6
1 1/4-12	A500-306	A500-104	A500-404	A500-205	-	-
1 1/2-12	A500-307	A500-105	A500-405	A500-206	-	-

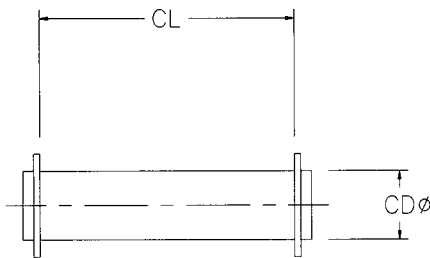

**Pivot Pin**

Part No.	CD	CL
A500-401	0.500	1.875
A500-402	0.750	2.625
A500-403	1.000	3.125
A500-404	1.375	4.125
A500-405	1.750	5.125

Included with mount codes P1, P2, P3 and P4

**Rod Couplers**

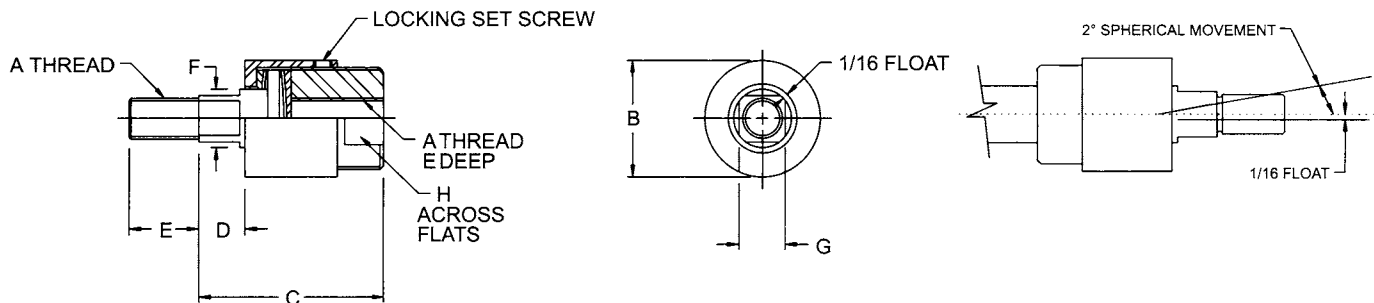

**Standard Couplers**

Part Number		A	B	C	D	E	F	G	H	Maximum Full Load
Standard	Nickel									
A500-603	B500-603	7/16-20	1 1/4	2	1/2	3/4	5/8	1/2	1	2,535
A500-604	B500-604	1/2-20	1 1/4	2	1/2	3/4	5/8	1/2	1	3,500
A500-605	B500-605	5/8-18	1 1/4	2	1/2	3/4	5/8	1/2	1	4,700
A500-606	B500-606	3/4-16	1 3/4	2 5/16	1/2	1 1/8	31/32	12/16	1 1/2	8,750
A500-607	B500-607	7/8-14	1 3/4	2 5/16	1/2	1 1/8	31/32	12/16	1 1/2	9,750
A500-608	B500-608	1-14	2 1/2	2 15/16	1/2	1 5/8	1 3/8	1 5/32	2 1/4	16,125
A500-609	B500-609	1 1/4-12	2 1/2	2 15/16	1/2	1 5/8	1 3/8	1 5/32	2 1/4	19,600
N35-1001	N35-1004	1 1/2-12	3 1/4	4 3/8	13/16	2 1/4	1 3/4	1 1/2	3	34,000



Dimensions: Inches

Accessories

Eye Bracket\*

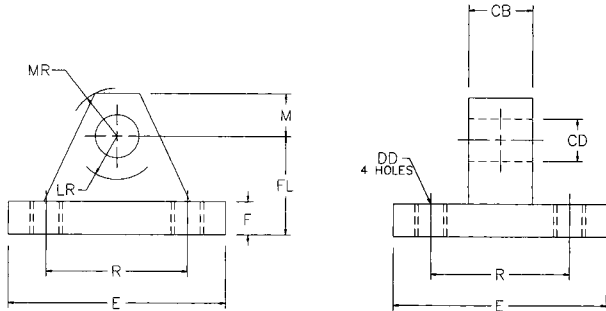

Rod Eye\*

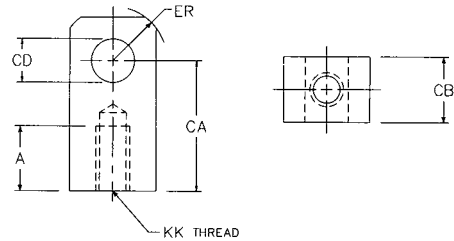

Clevis Bracket\*

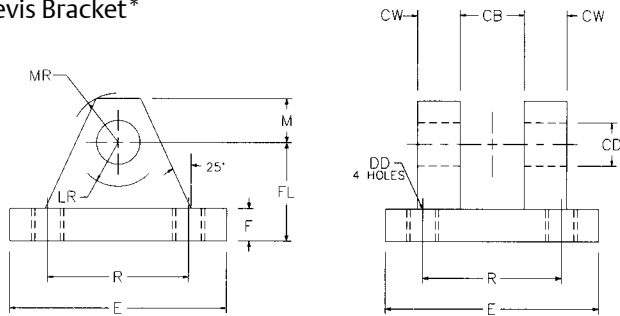

Rod Clevis\*

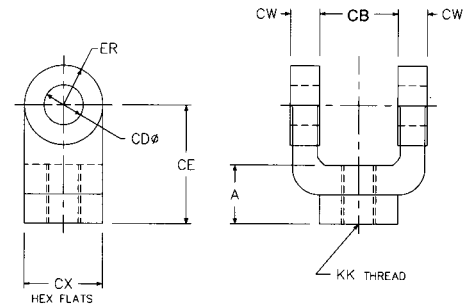

\*Order pivot pin separately.

Part No.	A	CA	CB	CD	CE	CW	CX	DD	E	ER	F	FL	KK	LR	M	MR	R
<b>Clevis Bracket</b>																	
A500-001	-	-	0.750	0.500	-	0.500	-	3/8-24	2.500	-	0.375	1.125	-	0.500	0.500	0.563	1.625
A500-002	-	-	1.250	0.750	-	0.625	-	1/2-20	3.500	-	0.625	1.875	-	1.063	0.750	1.063	2.563
A500-300	-	-	1.500	1.000	-	0.750	-	5/8-18	4.500	-	0.750	2.250	-	1.250	1.000	1.125	3.250
<b>Eye Bracket</b>																	
A500-101	-	-	0.750	0.500	-	-	-	0.406	2.500	-	0.375	1.125	-	0.750	0.500	0.563	1.630
A500-102	-	-	1.250	0.750	-	-	-	0.531	3.500	-	0.625	1.875	-	1.250	0.750	0.875	2.560
A500-103	-	-	1.500	1.000	-	-	-	0.656	4.500	-	0.750	2.250	-	1.500	1.000	1.250	3.250
A500-104	-	-	2.000	1.375	-	-	-	0.656	5.000	-	0.875	3.000	-	2.125	1.375	1.625	3.810
A500-105	-	-	2.500	1.750	-	-	-	0.906	6.500	-	0.875	3.125	-	2.250	1.750	2.125	4.950
<b>Rod Clevis</b>																	
A500-301	0.750	-	0.750	0.500	1.500	0.500	1.000	-	-	0.500	-	-	7/16-20	-	-	-	-
A500-302	0.750	-	0.750	0.500	1.500	0.500	1.000	-	-	0.500	-	-	1/2-20	-	-	-	-
A500-303	1.125	-	1.250	0.750	2.375	0.625	1.250	-	-	0.750	-	-	3/4-16	-	-	-	-
A500-304	1.625	-	1.500	1.000	3.125	0.750	1.500	-	-	1.000	-	-	7/8-14	-	-	-	-
A500-305	1.625	-	1.500	1.000	3.125	0.750	1.500	-	-	1.000	-	-	1-14	-	-	-	-
A500-306	2.000	-	2.000	1.375	4.125	1.000	2.000	-	-	1.375	-	-	1 1/4-12	-	-	-	-
A500-307	2.250	-	2.500	1.750	4.500	1.250	2.375	-	-	1.750	-	-	1 1/2-12	-	-	-	-
<b>Rod Eye</b>																	
A500-201	0.750	1.500	0.750	0.500	-	-	-	-	-	0.625	-	-	7/16-20	-	-	-	-
A500-202	0.750	1.500	0.750	0.500	-	-	-	-	-	0.625	-	-	1/2-20	-	-	-	-
A500-203	1.125	2.063	1.250	0.750	-	-	-	-	-	0.875	-	-	3/4-16	-	-	-	-
A500-204	1.625	2.813	1.500	1.000	-	-	-	-	-	1.188	-	-	1-14	-	-	-	-
A500-205	2.000	3.438	2.000	1.375	-	-	-	-	-	1.563	-	-	1 1/4-12	-	-	-	-
A500-206	2.250	4.000	2.500	1.750	-	-	-	-	-	2.000	-	-	1 1/2-12	-	-	-	-

**Accu A Series Piston Rod Assembly How To Order**

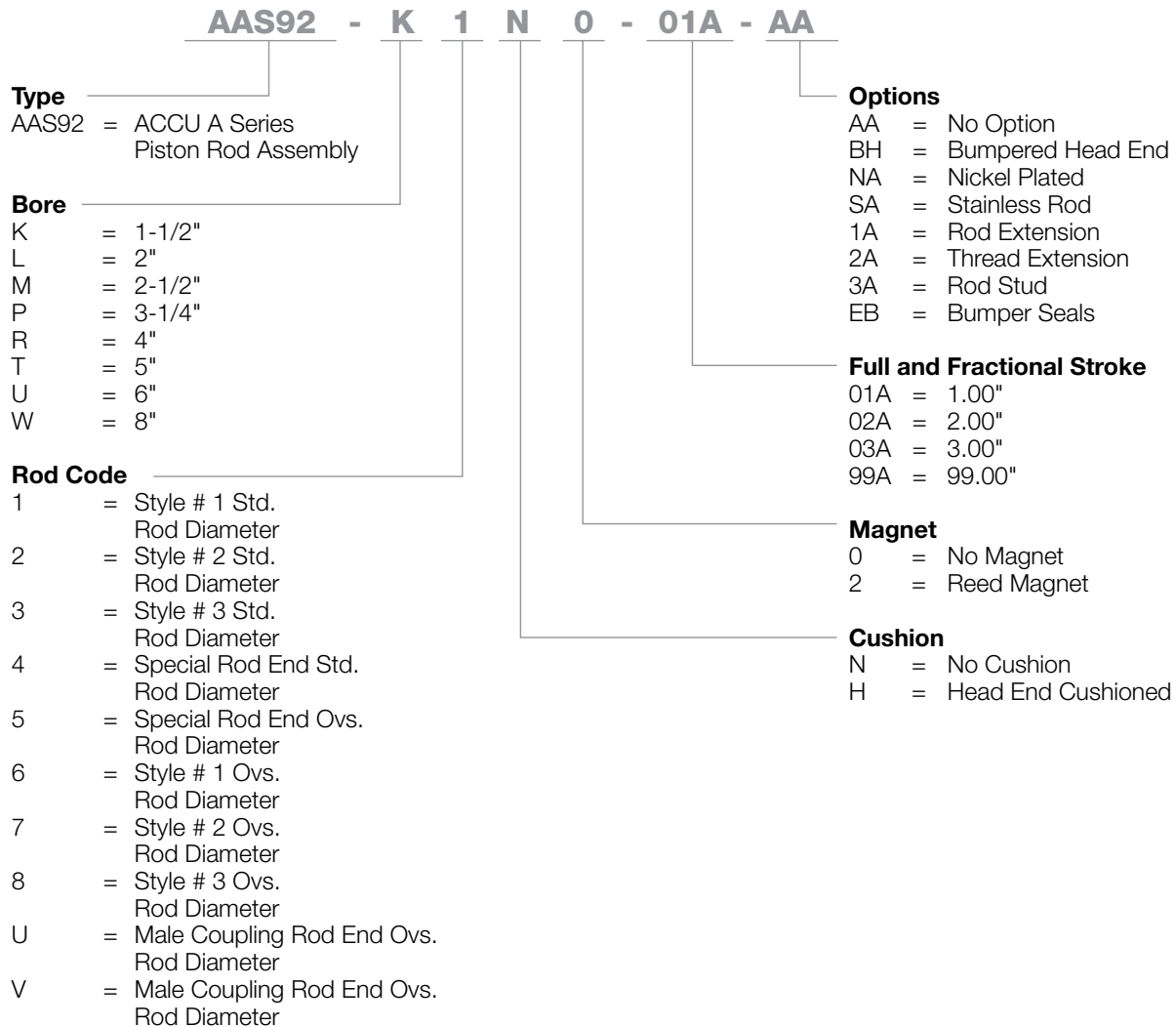

Note: Options listed are ones that apply to a piston rod assembly only.  
Model number is set up to use option code supplied with original cylinder or with any above.

**Repair Kit How To Order**

A Repair Kit includes all seals and a bushing.

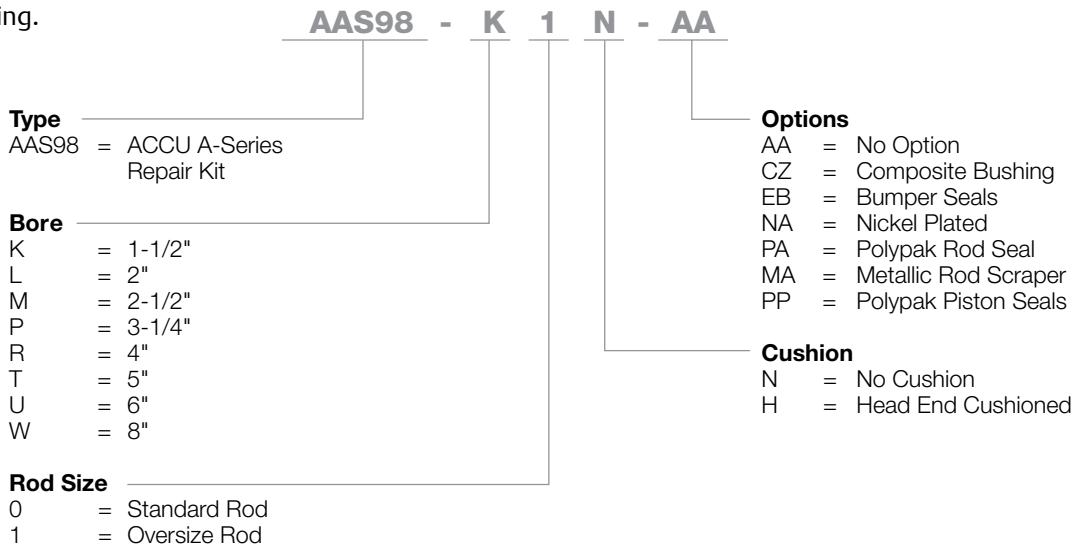

Note: Options listed are ones that apply to a repair kit only. Model number is set up to use option code supplied with original cylinder or with any above.

**Seal Kit How To Order**

A Seal Kit only includes the seals.

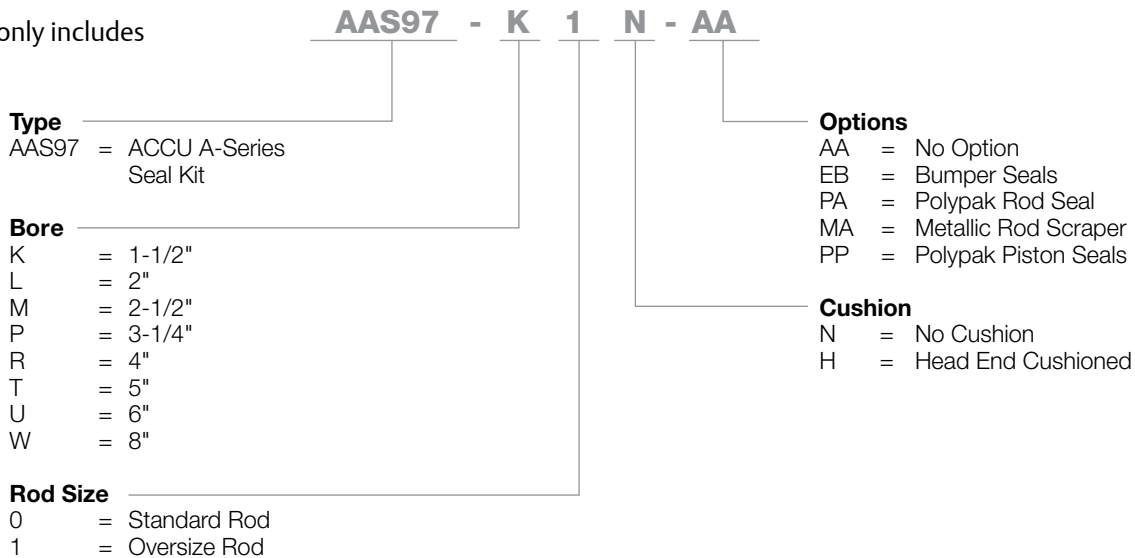

Note: Options listed are ones that apply to a seal kit only. Model number is set up to use option code supplied with original cylinder or with any above.

**Transducer Kit How To Order**



The **Accu M Series** is a stainless steel body air cylinder that contains an internal Linear Resistive Transducer (LRT). It is ideal for applications where traditional magnetic position sensing is not acceptable. Additionally, the Accu M Series is conducive where variations in cylinder stroke and speed are required or where an application calls for continuous position monitoring.

**Piston Rod**

The type 303 stainless steel piston rod is ground, polished, and roller burnished for a hard, mirror finish that will ensure long, corrosion-free longevity. (Note: The 1-1/16" bore is chrome plated 1050 steel.)

**Rod Thread**

Roll-formed rod threads (at both ends) ensure a durable customer-end connection as well as piston to rod connection.

**Rod Bushing**

Oil impregnated sintered bronze rod bushing provides excellent wear resistance and anti-friction qualities for smooth operation and long life.

**End Caps**

The end caps are made from a high strength aluminum alloy.

**Ports**

Unrestricted (full-flow) ports in conjunction with rectangular slots on the piston-mating surface (at both ends) enable the air to work on a larger piston area for effortless breakaway (even at low pressures).

**Tube**

The type 304 stainless steel tube, drawn and polished to a micro-inch finish on the I.D., enables low friction and longevity.

**Crimp**

The cylinder body is attached to the end caps using innovative assembly equipment that ensures a consistent and reliable double rolled-in crimp.

**Piston**

High strength aluminum alloy piston. Piston rod connections are threaded (roll-formed threads), sealed with Loctite Threadlocker®, torqued, and staked for a solid, leak-proof connection.

Threadlocker® is a registered trademark to the Loctite Corporation.

**Piston Seals**

Low friction Buna N "U" cup pistons seals are wear compensating for millions of maintenance free cycles.

**Rod Seal/Wiper**

The low friction Buna N "U" cup rod seal is wear compensating to ensure longevity.

**Cylinder Lubrication**

Pre-lubricated with our specially formulated oil based compound for extensive maintenance free performance.

**Linear Resistive Transducer (LRT) Probe**

The LRT is an anodized aluminum probe with a reinforced threaded flange and thread seal. The probe processes infinite resolution, with a non-linearity of ± 1 percent of full stroke.

Furthermore, the probe is rated for 10 million cycles. Typical probe input is 10VDC (maximum voltage is 28VDC and maximum current draw is less than 2mA), input impedance required is 1 Mohm. The probe temperature rating is -40° to 250° F. Maximum velocity is 50"/sec.



**Linear Resistive Transducer (LRT) Wiper**

The LRT wiper is precision molded assembly that is rated for more than 1000 linear miles of travel.

**3 Pin Connector**

The customer friendly connector is supplied as standard on all Accu A Series cylinders. The connector has a universal 8 mm, 3 pin, Nano male connection.

**Standard Specification:**

- 303 stainless steel piston rods are standard (except 1-1/16" bore)
- 304 stainless steel cylinder tube
- Aluminum head and caps
- Maximum pressure rating is 100 psi air
- Seven bore sizes – 1-1/16" – 3"
- Rod wipers
- Cylinder standard temperature -10° F to +165° F
- Probe Standard Temperature -40° F to +250° F
- Continuous position sensing
- Extremely accurate:
  - Infinite resolution, linearity of ± 1 percent of full stroke,
  - ± .001" mechanical repeatability
- Electronic controllers available for dual set points and scalable analog output applications
- Quick connect (IP65) standard on all models

MLRT Circuit Diagram

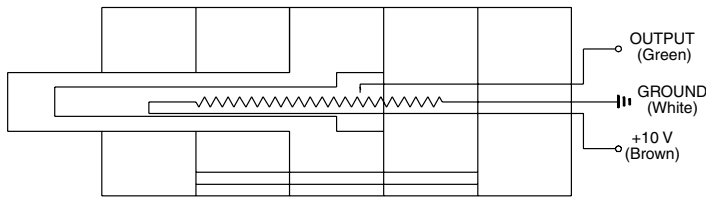

Connector Pin Assignments

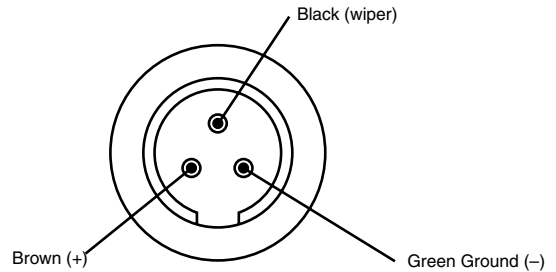

Note: Control Module Units sold separately can have scalable output of 4-20 mA or 0-10 VDC and input of 120 VAC or 12-24 VDC.

Connector Cable part number N99-1120

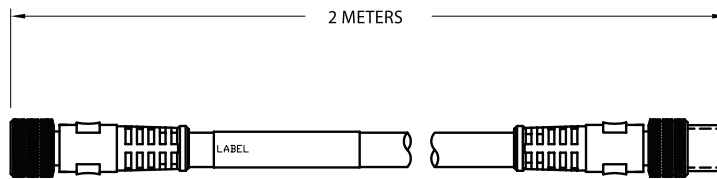

NOTE: SPECIAL CRISS-CROSS WIRING

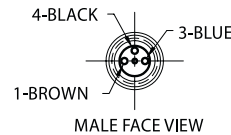
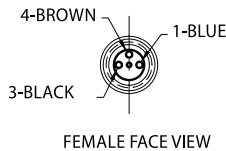

How To Order

**10 AM 1 - 06 A - 01**

<p><b>Cylinder Bore</b></p> <p>10 = 1-1/16" 15 = 1-1/2" 20 = 2" 25 = 2-1/2" 30 = 3"</p> <p><b>Cylinder Type</b></p> <p>AM = ACCU M Series</p> <p><b>Cylinder Mounting</b></p> <p>1 = Front Nose 2 = Rear Pivot 5 = Block Mount</p>	<p><b>Options</b></p> <p>00 = No Options (or leave blank) 01 = Bumpers Note: Bumpers add .125" to OAL per end.</p> <p><b>Fractional Inches of Stroke</b></p> <p>A = 0" I = 1/2"</p> <p><b>Standard Full Inches of Stroke</b></p> <p>01 = 1" Stroke 02 = 2" Stroke 03 = 3" Stroke 04 = 4" Stroke 06 = 6" Stroke 08 = 8" Stroke 12 = 12" Stroke 18 = 18" Stroke (Maximum)</p>
--	---

Note: Transducers are only available in the "Standard" strokes listed. Non-standard full inch or fractional strokes will use the smallest available "Standard" length transducer to cover the entire stroke. In these cases, the analog output will be less than 10V at full stroke.

Note: Non-standard stroke lengths will increase lead time.

Consult factory for fractional stroke information.



**Dimensions: Inches**

**Cylinder Dimensions**

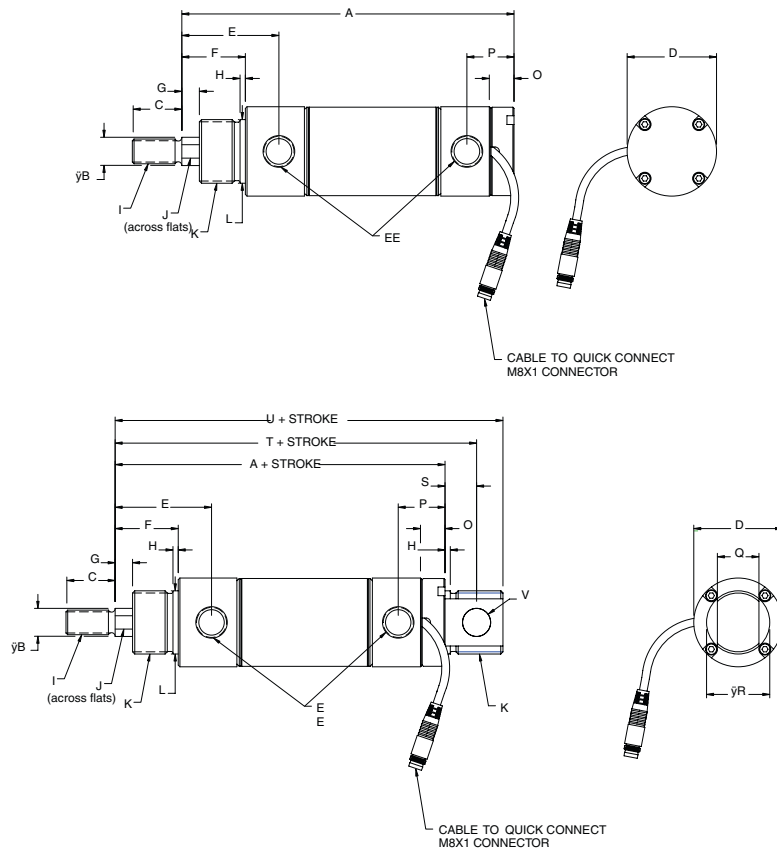

	<b>1-1/16" Bore</b>	<b>1-1/2" Bore</b>	<b>2" Bore</b>	<b>2-1/2" Bore</b>	<b>3" Bore</b>
A	4.59	4.88	5.46	6.41	6.78
B	0.38	0.50	0.63	0.75	0.75
C	0.63	0.88	1.00	1.25	1.25
D	1.312	1.56	2.08	2.63	3.16
E	1.75	1.72	1.92	2.25	2.16
F	1.06	1.13	1.188	1.50	1.438
G	0.31	0.31	0.38	0.44	0.44
H	0.09	0.09	0.13	0.13	0.19
I	5/16-24 UNF	7/16-20 UNF	1/2-20 UNF	5/8-18 UNF	5/8-18 UNF
J	0.31	0.44	0.50	0.63	0.63
K	7/8-14 UNF	1 1/8-12 UNF	1 1/4-12 UNF	1 3/8-12 UNF	1 1/2-12 UNF
L	0.875	1.125	1.375	1.500	1.625
O	0.44	0.41	0.50	0.56	0.63
P	0.84	0.83	0.93	1.13	1.47
Q	0.38	0.63	0.75	0.875	0.88
R	0.875	1.125	1.375	1.50	1.825
S	0.47	0.56	0.56	0.75	0.81
T	5.06	5.44	6.02	7.16	7.59
U	5.34	5.91	6.46	7.78	8.22
V	0.25	0.38	0.38	0.50	0.50
EE	1/8 NPTF	1/4 NPTF	1/4 NPTF	3/8 NPTF	3/8 NPTF



Dimensions: Inches

Block Mount Cylinder Dimensions

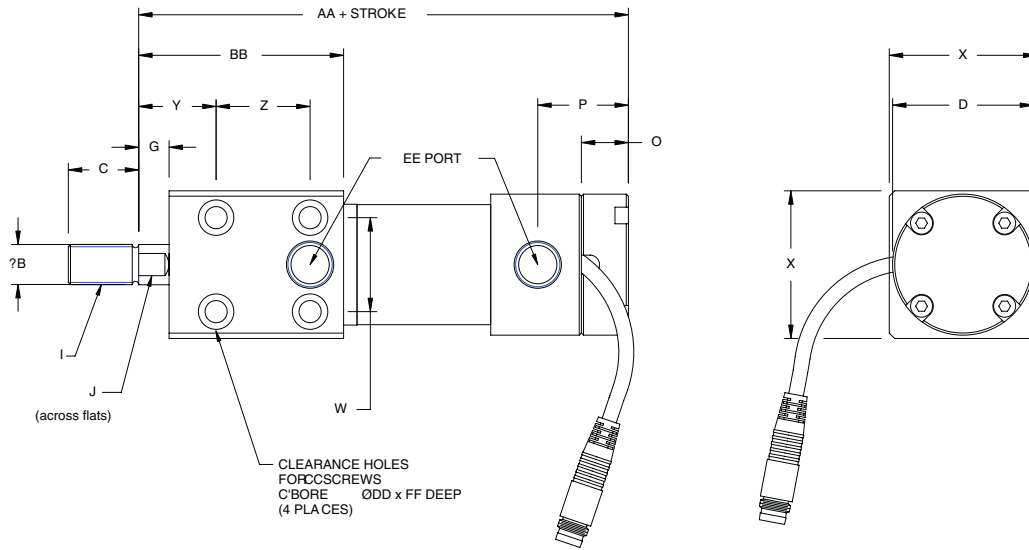

Bore	B	C	D	G	J	I	O	P	W	X	Y	Z	AA	BB	CC	DD	EE	FF
1-1/16	0.38	0.63	1.31	0.31	0.31	3/8-24	0.44	0.84	0.88	1.38	0.75	0.88	4.59	1.94	#10	0.33	1/8 NPTF	0.20
1-1/2	0.50	0.88	1.56	0.31	0.44	7/16-20	0.41	0.83	1.25	1.75	0.69	0.75	4.88	2.06	1/4	0.41	1/4 NPTF	0.25
2	0.63	1.00	2.08	0.38	0.50	1/2-20	0.50	0.93	1.44	2.25	0.75	1.00	5.72	2.71	3/8	0.58	1/4 NPTF	0.39
2-1/2	0.75	1.25	2.63	0.44	0.63	5/8-18	0.56	1.13	1.88	2.75	0.88	1.25	6.41	2.88	7/16	0.69	3/8 NPTF	0.45
3	0.75	1.25	3.16	0.44	0.63	5/8-18	0.63	1.47	2.25	3.25	0.94	1.38	6.78	2.75	1/2	0.77	3/8 NPTF	0.52

**Accessories**

**Nose Mounting Brackets**

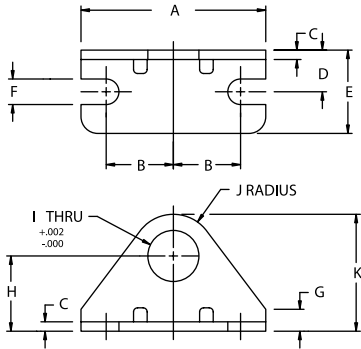

Bore	A	B	C	D	E	F	G	H	I	J	K	Part #
1-1/16	2.13	0.781	0.16	0.66	1.16	0.28	0.32	1.00	0.88	0.75	1.75	M117013
1-1/2	2.75	1.06	0.19	0.81	1.44	0.34	0.38	1.25	1.13	0.91	2.19	M117012
2	3.13	1.13	0.25	1.00	1.63	0.34	0.63	1.50	1.38	1.00	2.50	M117009
2-1/2	3.75	1.44	0.25	1.00	1.63	0.34	0.75	1.75	1.50	1.25	3.00	M117010
3	4.38	1.75	0.25	1.00	1.63	0.34	0.89	1.89	1.63	1.25	3.14	M117011

**Pivot Mounting Brackets**

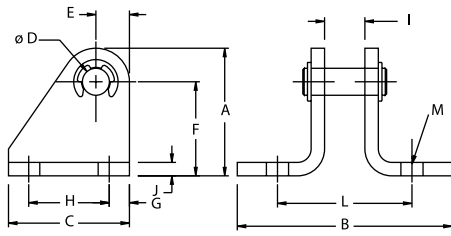

Bore	A	B	C	D	E	F	G	H	I	J	L	Part #
1-1/16	1.19	2.00	1.13	0.25	0.31	0.88	0.19	0.75	0.38	0.13	1.25	M129003
1-1/2	1.75	2.88	1.50	0.38	0.38	1.38	0.25	1.00	0.63	0.25	2.00	M129005
2	1.75	3.00	1.50	0.38	0.38	1.38	0.25	1.00	0.63	0.25	2.13	M229005
2-1/2	2.25	3.88	1.75	0.50	0.50	1.75	0.25	1.25	0.88	0.25	2.63	M229005
3	2.25	3.88	1.75	0.50	0.50	1.75	0.25	1.25	0.88	0.25	2.63	M229006

**Rod Clevises**

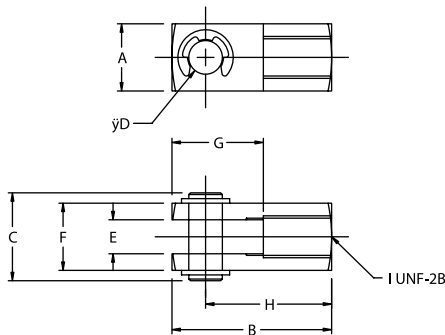

Bore	A	B	C	D	E	F	G	H	I	Part #
1-1/16	0.50	1.19	0.68	0.25	0.25	0.50	0.68	0.94	5/16-24	M127004
1-1/2	0.75	1.69	1.03	0.38	0.38	0.75	0.94	1.31	7/16-20	M127005
2	0.75	1.69	1.03	0.38	0.38	0.75	0.94	1.31	1/2-20	M127006
2-1/2	1.00	2.75	1.28	0.50	0.50	1.00	1.50	2.25	5/8-18	M127006
3	1.00	2.75	1.28	0.50	0.50	1.00	1.50	2.25	5/8-18	M127007

**Mounting Nuts**

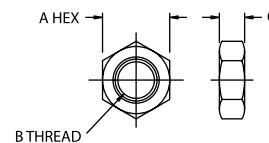

Part #	A	B	C
M18-004	0.50	5/16-24	0.19
M190003	0.687	7/16-20	0.25
M190004	0.750	1/2-20	0.31
M190005	0.938	5/8-18	0.38
M190007	1.312	7/8-14	0.48
M190015	1.688	1 1/8-12	0.61
M190009	1.875	1 1/4-12	0.50
M190012	2.06	1 3/8-12	0.50
M190013	2.25	1 1/2-12	0.84

**Transducer Kit How To Order**

**M72-E02M - 01A**

**Type**  
M72-E02M = ACCU A & ACCU M  
Transducer

**Cylinder Stroke**  
01A = 1.000  
02A = 2.000  
03A = 3.000  
99A = 99.000

The **Accu Slide Series** is a pneumatic slide that is driven by a cylinder that contains an internal Linear Resistive Transducer (LRT). It enables position feedback capability for applications where space is limited and when a load must be guided to prevent rotation.

**A. Body:**

**Hardcoat Anodized Aluminum(6061-T6511)**

Lightweight, durable, high strength to weight ratio.

**Standard Dowel Location Holes**

Allows precision mounting.

**Multi-Surface Mounting Holes**

Flexible, easy access for mounting.

**B. Air Cylinder (ACCU M Series):**

**Standard Stainless Steel Body and Rod**

Corrosion resistant.

**Standard w/ Magnetic Piston**

Sensing applications (Hall, Reed or Prox) added as required.

**C. Alignment Coupler:**

**Isolates Piston Rod from side loading**

Maximize life of cylinder, 360 degrees of float.

**D. Tooling Plate:**

**NuMate Universal Mounting Pattern**

Standardized mounting system, eliminates custom transition plates.

**Holes Drilled/Tapped and C'bored from the opposite side**

Easy mounting.

**Standard Dowel Locating Holes**

Precision mounting.

**E. Guide Shafts:**

**Hardened Steel to Rc 60 - 65**

Long life.

**Hardened Stainless Steel to Rc 50 - 55**

Long life.

**Precision Ground & Polished to 15uRMS**

Smooth cycling/low breakaway.

**Pilot Mounted to Tooling Plate**

Maximum rigidity.

**Large Diameters**

Increased load capacity.

**F. Bearings: (Three Choices)**

**Four Precision Linear Ball Bearings Sealed with Rod Wipers**

Safe guarding against dirt & contamination.

**Self-Aligning**

Reducing wear, maximizing both. load capacity and long life.

**Four Sintered Bronze Sleeve Bearings Oil Impregnated**

Self lubricating.

**High Pv Rating**

Long service life.

**Four Frelon® Compounded PTFE Low Friction**

Longest wear life.

**Maintenance Free**

Self lubricating.

**G. Bumpers: (Standard)**

**Polyurethane Material**

Durable and long lasting.

**Integrated into body Design**

Reduces shock loading on extend & retract.

**Preliminary Rod Wiper**

Removes larger contamination from Guide Shafts.

**H. Adjustable Shaft Collars: (Standard)**

**Extend Stroke Adjustment**

Flexibility.

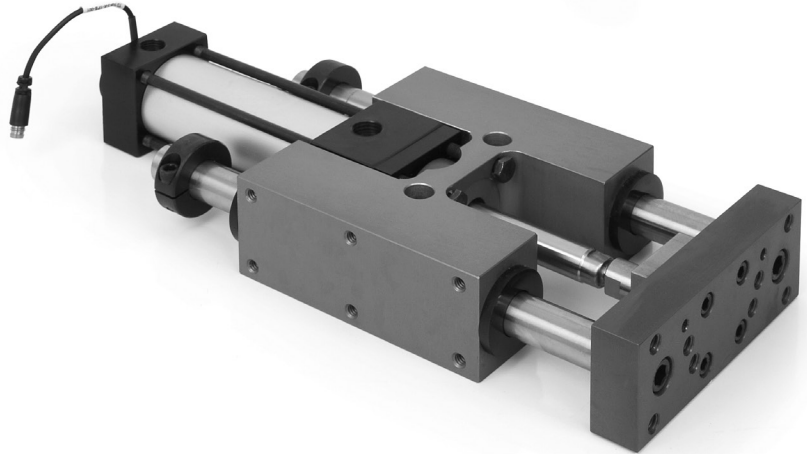

The **Accu Gantry Series** is a pneumatic gantry slide that is driven by a cylinder that possesses an internal Linear Resistive Transducer (LRT). It enables position feedback capability for applications that require fundamental gantry motion.

The design centers around a moving carriage between two fixed tool bars. The carriage is supported and guided by four bearings and two hardened guide shafts.

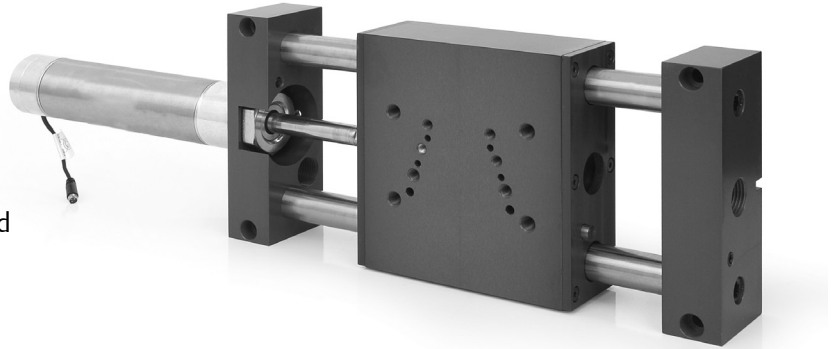

**A. Carriage:**

**Hardcoat Anodized Aluminum**

Lightweight, high durability. NuMate Direct Mounting Pattern NuMate is a patented mounting system eliminating the need for adaptor/transition plates. Slide, gantries and grippers mount directly to the GS gantry.

**B. Air Cylinder:**

**Standard Stainless Steel Body and Rod**

Corrosion resistant.

**Standard Magnetic Piston**

Sensing options Reed, Hall, Prox sensors, able to be added in field.

**C. Alignment Coupler:**

**360 Degrees of Float**

Isolates cylinder, eliminates destructive side load, maximizes life.

**D. Tool Bars:**

**Standard Dowel Locating Hole and Slot**

Accurate mounting and positioning.

**Standard Tapped Holes for Shock Absorbers**

Accepts industry standard shocks.

**E. Guide Shafts: (Two Choices)**

**Hardened Steel**

Hardness Rc 60-65, long life.

**Hardened Stainless Steel**

Hardness Rc 50-55, corrosion resistant.

**Precision Ground and Polished 15u RMS**

Smooth cycling, low breakaway.

**Large Diameter**

Increased load capacity.

**Pilot Mounted to Tool Bar**

Maximum rigidity, increased strength.

**F. Bearings: (Two Choices)**

**Four Linear Ball Bearings**

Greatest load capacity, self-lubricating, built-in seals and wipers, self-aligning.

**Four Frelon® Compounded PTFE**

Self-lubricating, self-aligning, long service life, ideal for cleanroom.

**G. Stroke Adjustment Screws:**

**Standard Extend and Retract**

Fine adjustment for carriage travel.



# Efficient pneumatic solutions: cylinders and drives, valves and valve systems, air supply management



**AVENTICS™**

Visit us: [Emerson.com/AVENTICS](https://www.emerson.com/AVENTICS)

Your local contact: [Emerson.com/contactus](https://www.emerson.com/contactus)



[Emerson.com](https://www.emerson.com)



[Facebook.com/EmersonAutomationSolutions](https://www.facebook.com/EmersonAutomationSolutions)



[LinkedIn.com/company/Emerson-Automation-Solutions](https://www.linkedin.com/company/Emerson-Automation-Solutions)



[Twitter.com/EMR\\_Automation](https://twitter.com/EMR_Automation)

The Emerson logo is a trademark and service mark of Emerson Electric Co. Brand logotype are registered trademarks of one of the Emerson family of companies. All other marks are the property of their respective owners. © 2021 Emerson Electric Co. All rights reserved.  
TR000325ENUS-01\_06-21

  
**EMERSON™**

**CONSIDER IT SOLVED™**